

EAT•N**Cutler-Hammer****Quick Reference Guide**

For NFX9000 Adjustable Frequency Drives

February 2006



5011640900



NQ00

Hazardous High Voltage

WARNING

Motor control equipment and electronic controllers are connected to hazardous line voltages. When servicing drives and electronic controllers, there may be exposed components with housings or protrusions at or above line potential. Extreme care should be taken to protect against shock.

- Stand on an insulating pad and make it a habit to use only one hand when checking components.
- Always work with another person in case an emergency occurs.
- Disconnect power before checking controllers or performing maintenance.
- Be sure equipment is properly grounded.
- Wear safety glasses whenever working on electronic controllers or rotating machinery.

Power and Control Wiring

Basic Wiring

- Use power terminals R/L1 and S/L2 for single-phase connection to models: NFXF25A0-1, NFXF50A0-1, NFXF25A0-2, NFXF50A0-2 or NFX001A0-2.
- Use power terminals R/L1, S/L2 and T/L3 for three-phase connection to models: NFXF25A0-2, NFXF50A0-2, NFX001A0-2 or NFX002A0-2.
- Single-phase power must not be used for model NFX002A0-2.

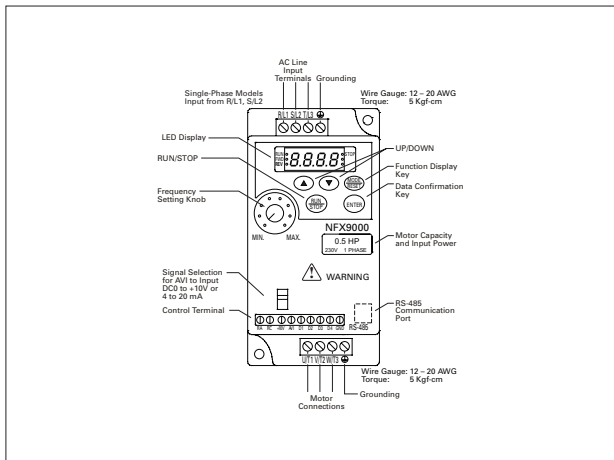

Main Circuit Wiring

Wire Type: 75°C Copper Only

Catalog Number	Voltage / Horsepower	Max. Current (A) (Input/Output)	Wire Gauge (AWG)	Torque Rating (kgf-cm)
NFXF25A0-1 (1-phase)	115V AC, 1/4 hp	6.0/1.6	12 - 16	5
NFXF50A0-1 (1-phase)	115V AC, 1/2 hp	9.0/2.5	12 - 14	5
NFXF25A0-2 (1-phase)	230V AC, 1/4 hp	4.9/1.6	12 - 16	5
NFXF50A0-2 (1-phase)	230V AC, 1/2 hp	6.5/2.5	12 - 16	5
NFX001A0-2 (1-phase)	230V AC, 1 hp	9.7/4.2	12 - 14	5
NFX002A0-2 (3-phase)	230V AC, 2 hp	9.0/7.0	12 - 14	5

Users must connect wiring according to the circuit diagram shown below. Please follow all national and state wiring codes when wiring the drive.

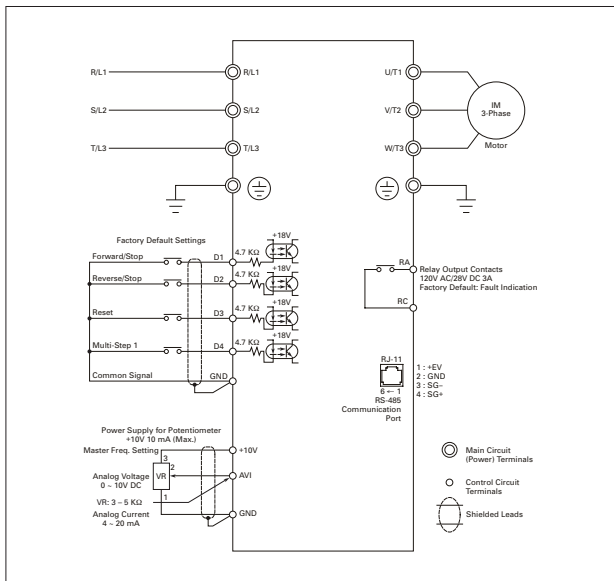

Basic Wiring

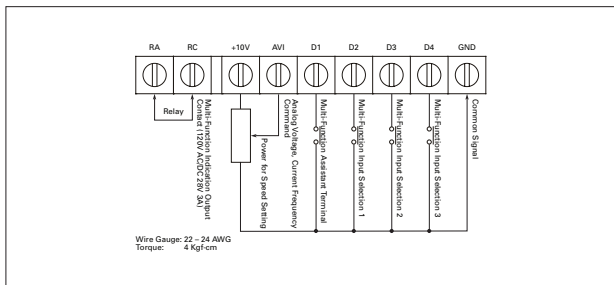

Control Circuit Wiring

Wiring Notes

WARNING

Ensure that all screws are tightened to the proper torque rating.

CAUTION

Do not connect the AC input to any of the U/T1, V/T2 or W/T3 terminals as it will damage the drive.

Multiple NFX9000 drives can be installed in one location. Please read the following prior to installation:

1. Follow all national and local electrical, construction and safety codes during installation.
2. Ensure the appropriate protective devices (circuit breaker or fuses) are connected between the power supply and drive.
3. Make sure the leads are connected correctly and the drive is properly grounded. (Ground resistance should not exceed .1 Ω .)
4. Use ground leads that comply with AWG/MCM standards and keep them as short as possible.
5. For multiple drive installations, make sure to ground all units directly to a common ground terminal. The ground terminals may be connected in parallel as shown below. (Ensure there are no ground loops.)

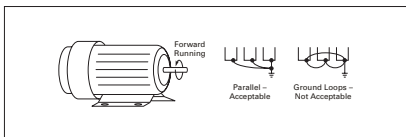

Ground Terminals Connected in Parallel

6. For normal operation, make sure drive output terminals U/T1, V/T2 and W/T3 are connected to motor terminals U, V and W (respectively). The motor will rotate counterclockwise as viewed from the shaft ends of the motor when a forward operation command is received. To reverse the direction of motor rotation, switch any two of the motor leads.
7. Make sure the power source is capable of supplying the correct voltage and required current to the drive.
8. Do not attach or remove wiring when power is applied to the drive.
9. Do not monitor the signals on the circuit board while the drive is in operation.
10. Route the power and control wires separately or at right angles to each other.
11. If required to reduce electro-magnetic interference (EMI), install the filter as close as possible to the U/T1, V/T2 or W/T3 side of the drive.
Note: Do not use a capacitor or L-C filter (inductance/capacitance) or an R-C filter (resistance/capacitance).
12. When using a GFCI (ground fault circuit interrupt), select a current sensor with a minimum current of 200 mA and a minimum detection time of .1 second to avoid nuisance tripping.

Parameters

Parameter Lists

Group 0 — User Parameters

Code	Parameter	Min.	Max.	Unit	Default	Note
0-00	Identity code of drive (read only)	1	6			1: 40W 2: 100W 3: 200W 4: 400W 5: 750W 6: 1.5 kW
0-01	Rated current display (read only)	—	—			40W: .4A 100W: .8A 200W: 1.6A 400W: 2.5A 750W: 4.2A 1.5 kW: 7.0A
0-02	Parameter reset				0	10: Reset parameters to factory setting
0-03 [Ⓢ]	Start-up display of drive	0	3		0	0: F (frequency command) 1: H (output frequency) 2: U (user-defined unit) 3: A (output current)
0-04 [Ⓢ]	User-defined unit	0	4		0	0: Display user-defined unit (u) 1: Display counter value (C) 2: Display process operation (1=tt) 3: Display DC bus voltage (U) 4: Display output voltage (E)
0-05 [Ⓢ]	User-defined coefficient (K)	0.1	160		1.0	0.1 – 160
0-06	Software version	—	—		#.#	Read only
0-07	Password input	0	999		0	0 – 999
0-08	Password configuration	0	999		0	0 – 999

[Ⓢ] The parameter may be set during operation.

Group 1 — Basic Parameters

Code	Parameter	Min.	Max.	Unit	Default	Note
1-00	Maximum operation frequency	50.0	400	Hz	60.0	50.0 – 400 Hz
1-01	Maximum voltage frequency	10.0	400	Hz	60.0	10.0 – 400 Hz
1-02	Maximum output voltage	2.0	255	V	220	2.0 – 255V
1-03	Mid-point frequency	1.0	400	Hz	1.0	1.0 – 400 Hz
1-04	Mid-point voltage	2.0	255	V	12.0	2.0 – 255V
1-05	Minimum output frequency	1.0	60.0	Hz	1.0	1.0 – 60 Hz
1-06	Minimum output voltage	2.0	255	V	12.0	2.0 – 255V
1-07	Upper bound of frequency	1	110	%	100	1 – 110%
1-08	Lower bound of frequency	0	100	%	0	0 – 100%
1-09 [Ⓢ]	Acceleration time 1 (Tacc1)	0.1	600	sec.	10.0	0.1 – 600 seconds
1-10 [Ⓢ]	Deceleration time 1 (Tdec1)	0.1	600	sec.	10.0	0.1 – 600 seconds
1-11 [Ⓢ]	Acceleration time 2	0.1	600	sec.	10.0	0.1 – 600 seconds
1-12 [Ⓢ]	Deceleration time 2	0.1	600	sec.	10.0	0.1 – 600 seconds
1-13 [Ⓢ]	JOG acceleration time	0.1	600	sec.	10.0	0.1 – 600 seconds
1-14 [Ⓢ]	JOG deceleration time	0.0	600	sec.	10.0	0.0 – 600 seconds
1-15 [Ⓢ]	JOG frequency	1.0	400	Hz	6.0	1.0 – 400 Hz
1-16	Auto acceleration/ deceleration	0	5		0	0: Linear accel./decel. 1: Auto accel., linear decel. 2: Linear accel., auto decel. 3: Auto accel./decel. 4: Linear accel., auto decel. (stall prevention during deceleration) 5: Auto accel./decel. (stall prevention during deceleration)
1-17	S-curve setting in acceleration	0	7		0	0 – 7
1-18	S-curve setting in deceleration	0	7		0	0 – 7

[Ⓢ] The parameter may be set during operation.

Group 2 — Operation Method Parameters

Code	Parameter	Min.	Max.	Unit	Default	Note
2-00	Source of frequency command	0	4		0	0: Digital keypad 1: 0 – 10V from AVI 2: 4 – 20 mA from AVI 3: Controlled by V.R. on drive 4: RS-485 communication interface
2-01	Source of operation command	0	4		0	0: By digital keypad 1: By external terminals, keypad STOP enable 2: By external terminals, keypad STOP disable 3: By RS-485 communication interface, keypad STOP enable 4: By RS-485 communication interface, keypad STOP disable
2-02	Stop method	0	1		0	0: Ramp stop 1: Coast stop
2-03	Carrier frequency	3	10K	Hz	10	3 – 10K Hz
2-04	Reverse operation inhibit	0	2		0	0: Enable reverse 1: Disable reverse 2: Disable forward
2-05	ACI (4 – 20 mA) input loss detection	0	2		0	0: Decelerate to 0 Hz 1: Stop immediately, display EF 2: Run with the last frequency
2-06	Line start lockout	0	1		0	0: Enable 1: Disable

Group 3 — Output Function Parameters

Code	Parameter	Min.	Max.	Unit	Default	Note
3-00	Desired frequency attained	1.0	400	Hz	1.0	1.0 – 400 Hz
3-01	Terminal count value	0	999		0	0 – 999
3-02	Preliminary count value	0	999		0	0 – 999
3-03	Multi-function relay output	0	16		8	0: Not used 1: AC drive operational 2: Maximum output frequency attained 3: Zero speed 4: Over torque 5: Base-block (B.B.) 6: Low voltage detection 7: AC drive operation mode 8: Fault indication 9: Desired frequency attained 10: PLC program running 11: PLC program step complete 12: PLC program complete 13: PLC program operation pause 14: Terminal count value attained 15: Preliminary count value attained 16: Ready state indicator

Group 4 — Input Function Parameters

Code	Parameter	Min.	Max.	Unit	Default	Note
4-00 [Ⓢ]	Potentiometer bias frequency	0.0	350	Hz	0.0	0.0 – 350 Hz
4-01 [Ⓢ]	Potentiometer bias polarity	0	1		0	0: Positive bias 1: Negative bias
4-02 [Ⓢ]	Potentiometer frequency gain	1	200	%	100	1 – 200
4-03	Potentiometer reverse motion enable	0	2		0	0: Not used 1: Reverse motion enable 2: Forward motion only
4-04	Digital Input 1 & 2 (D1 & D2)	0	3		1	0: Not used 1: D1 – FWD/STOP, D2 – REV/STOP 2: D1 – RUN/STOP, D2 – FWD/REV 3: D1, D2, D3 – 3-wire operation control mode
	Note: Setting parameter 4-04 to values 4 – 20 applies to D2 and disables D1	4	20		—	4: External fault, normally open (NO) 5: External fault, normally closed (NC) 6: Reset 7: Multi-step speed command 1 8: Multi-step speed command 2 9: Jog operation 10: Accel./decel. speed inhibit 11: First or second accel./decel. time selection 12: Base block, NO 13: Base block, NC 14: Increase master frequency 15: Decrease master frequency 16: Run PLC program 17: Pause PLC 18: Counter trigger signal 19: Counter reset 20: Select ACI/deselect AVI

[Ⓢ] The parameter may be set during operation.

Group 4 — Input Function Parameters, continued

Code	Parameter	Min.	Max.	Unit	Default	Note
4-05	Digital Input 3 (D3) Note: Setting parameter 4-04 to value 3 presets D3 to 3-wire operation	0, 4	20		6	0: Not used 4: External fault, normally open (NO) 5: External fault, normally closed (NC) 6: Reset 7: Multi-step speed command 1 8: Multi-step speed command 2 9: Jog operation 10: Accel./decel. speed inhibit 11: First or second accel./decel. time selection 12: Base block, NO 13: Base block, NC 14: Increase master frequency 15: Decrease master frequency 16: Run PLC program 17: Pause PLC 18: Counter trigger signal 19: Counter reset 20: Select ACI/deselect AVI
4-06	Digital Input 4 (D4)	0, 4	20		7	Same as 4-05.

Group 5 — Multi-Step Speed and PLC Parameters

Code	Parameter	Min.	Max.	Unit	Default	Note
5-00	First step speed frequency	0.0	400	Hz	0	0 – 400 Hz
5-01	Second step speed frequency	0.0	400	Hz	0	0 – 400 Hz
5-02	Third step speed frequency	0.0	400	Hz	0	0 – 400 Hz
5-03	PLC mode	0	4		0	0: Disable PLC operation 1: Execute one program cycle 2: Continuously execute program cycles 3: Execute one program cycle step by step (separate by STOP) 4: Continuously execute one program cycle step by step (separate by STOP)
5-04	PLC forward/reverse motion	0	1		0	0 – 15 0: Forward 1: Reverse
5-05	Time duration step 0	0	65500	sec.	0	0 – 65500 seconds
5-06	Time duration step 1	0	65500	sec.	0	0 – 65500 seconds
5-07	Time duration step 2	0	65500	sec.	0	0 – 65500 seconds
5-08	Time duration step 3	0	65500	sec.	0	0 – 65500 seconds

Group 6 — Protection Parameters

Code	Parameter	Min.	Max.	Unit	Default	Note
6-00	Over-voltage prevention level	0	410	V	390	0: Disable, 350 – 410V
6-01	Over-current prevention level	0	200	%	170	0: Disable, 20 – 200%
6-02	Over-torque detection	0	4		0	0: Disable 1: Enabled during constant speed operation; continues until the continuous limit is reached 2: Enabled during constant speed operation; halted after detection 3: Enabled during acceleration; continues before continuous output time limit is reached 4: Enabled during acceleration; halted after over-torque detection
6-03	Over-torque detection level	30	200	%	150	30 – 200%
6-04	Over-torque detection time	0.1	10.0	sec.	0.1	0.1 – 10.0 seconds
6-05	Electronic thermal overload relay	0	2		0	0: Not used 1: Act with standard motor 2: Act with special motor
6-06	Electronic thermal characteristic	30	600	sec.	60	30 – 600 seconds

Group 6 — Protection Parameters, continued

Code	Parameter	Min.	Max.	Unit	Default	Note
6-07	Present fault record	0	11		0	0: No fault occurred 1: oc (over-current) 2: ov (over-voltage) 3: oH (overheat) 4: oL (overload) 5: oL1 (electronic thermal) 6: EF (external fault) 7: Reserved 8: Reserved 9: ocA (current exceed during acceleration) 10: ocd (current exceed during deceleration) 11: ocn (current exceed during steady state) 12: Reserved 13: Reserved 14: Reserved 15: CPU failure 1 (cF1) 16: CPU failure 2 (cF2) 17: Reserved 18: Overload (oL2) 19: Auto acc/dec failure (cFA) 20: Software protection enabled (code) 21: Reserved 22: CPU failure (cF3.1) 23: CPU failure (cF3.2) 24: CPU failure (cF3.3) 25: CPU failure (cF3.4) 26: CPU failure (cF3.5) 27: CPU failure (cF3.6) 28: CPU failure (cF3.7) 29: Hardware protection failure (HPF.1) 30: Hardware protection failure (HPF.2) 31: Hardware protection failure (HPF.3)
6-08	Second most recent fault record	0	11		0	Same as 6-07
6-09	Third most recent fault record	0	11		0	Same as 6-07
6-10	Fourth most recent fault record	0	11		0	Same as 6-07
6-11	Fifth most recent fault record	0	11		0	Same as 6-07
6-12	Sixth most recent fault record	0	11		0	Same as 6-07

Group 7 — Motor Parameters

Code	Parameter	Min.	Max.	Unit	Default	Note
7-00 [Ⓢ]	Motor-rated current	30	120	%	85	30 – 120%
7-01 [Ⓢ]	Motor no-load current	0	90	%	50	0 – 90%
7-02 [Ⓢ]	Torque compensation	0	10		1	0 – 10
7-03 [Ⓢ]	Slip compensation	0.0	10.0		0.0	0.0 – 10.0

[Ⓢ] The parameter may be set during operation.

Group 8 — Special Parameters

Code	Parameter	Min.	Max.	Unit	Default	Note
8-00	DC braking voltage level	0	30	%	0	0 – 30%
8-01	DC braking time during start-up	0.0	60.0	sec.	0.0	0.0 – 60.0 seconds
8-02	DC braking time during stopping	0.0	60.0	sec.	0.0	0.0 – 60.0 seconds
8-03	Start point for DC braking	0.0	400.0	sec.	0.0	0.0 – 400.0 seconds
8-04	Momentary power loss	0	2		0	0: Stop operation after momentary power loss 1: Continues after momentary power loss; speed search starts with master frequency 2: Continues after momentary power loss; speed search starts with minimum output frequency
8-05	Maximum allowable power loss time	0.3	5.0	sec.	2.0	0.3 – 5.0 seconds
8-06	Base-block time for speed search	0.3	5.0	sec.	0.5	0.3 – 5.0 seconds
8-07	Maximum speed search current level	30	200	%	150	30 – 200%
8-08	Skip frequency 1 upper bound	0.0	400	Hz	0.0	0.0 – 400 Hz
8-09	Skip frequency 1 lower bound	0.0	400	Hz	0.0	0.0 – 400 Hz
8-10	Skip frequency 2 upper bound	0.0	400	Hz	0.0	0.0 – 400 Hz
8-11	Skip frequency 2 lower bound	0.0	400	Hz	0.0	0.0 – 400 Hz
8-12	Skip frequency 3 upper bound	0.0	400	Hz	0.0	0.0 – 400 Hz

Group 8 — Special Parameters, continued

Code	Parameter	Min.	Max.	Unit	Default	Note
8-13	Skip frequency 3 lower bound	0.0	400	Hz	0.0	0.0 – 400 Hz
8-14	Auto restart after fault	0	10		0	0 – 10
8-15	AVR function	0	2		2	0: AVR function enabled 1: AVR function disabled 2: AVR function disabled with deceleration
8-16	Dynamic braking voltage	350	450	V	380	350 – 450V
8-17	DC braking lower bound limit	0.0	400	Hz	0.0	0.0 – 400 Hz

Group 9 — Communication Parameters

Code	Parameter	Min.	Max.	Unit	Default	Note
9-00 [Ⓞ]	Communication address	1	247		1	1 – 247
9-01 [Ⓞ]	Transmission speed	0	2		1	0: Baud rate 4,800 1: Baud rate 9,600 2: Baud rate 19,200
9-02 [Ⓞ]	Transmission fault treatment	0	3		0	0: Warn and continue running 1: Warn and ramp to stop 2: Warn and coast to stop 3: No warning and keep running
9-03 [Ⓞ]	Modbus communication watchdog timer	0	20		0	0: Disable, 1 – 20: 1 – 20 seconds
9-04 [Ⓞ]	Communication protocol	0	8		0	ASCII mode: 0: 7,N,2 1: 7,E,1 2: 7,O,1 3: 8,N,2 4: 8,E,1 5: 8,O,1 RTU mode: 6: 8,N,2 7: 8,E,1 8: 8,O,1

[Ⓞ] The parameter may be set during operation.

Fault Codes

The NFX9000 drive has a comprehensive fault diagnostic system that includes several different alarms and fault messages. Once a fault is detected, the corresponding protective functions will be activated. The following faults are displayed on the AC drive digital keypad. The six most recent faults can be read on the digital keypad display by viewing Parameter 6-07 to Parameter 6-12.

Note: Faults can be cleared by pressing the RESET key on the keypad or Input Terminal.

Common Problems and Solutions

Fault Name	Fault Description	Corrective Action
oc	Drive detects an abnormal increase in current	<ol style="list-style-type: none"> 1. Make sure the motor's horsepower corresponds to the drive's output power. 2. Check the wiring connections between the drive and motor for possible short circuits. Note: If there are any abnormal conditions when operating the drive after the short circuit is removed, consult Eaton. 3. Increase the acceleration time (parameters 1-09 and 1-11). 4. Check for possible excessive loading.
ou	Drive detects that DC bus voltage has exceeded its maximum allowable value	<ol style="list-style-type: none"> 1. Make sure the input voltage falls within the drive's input voltage rating range. 2. Check for possible voltage transients. 3. Increase the deceleration time. (Bus overvoltage may also be caused by motor regeneration.)
oH	Drive's temperature sensor detects excessive heat	<ol style="list-style-type: none"> 1. Ensure that the ambient temperature falls within the specified temperature range. 2. Make sure that the ventilation holes are not obstructed. 3. Remove any foreign objects on the heat-sink and check for possible dirty heat-sink fins. 4. Provide enough spacing for adequate ventilation.
Lu	Drive detects that DC bus voltage has fallen below its minimum value	Make sure the input voltage falls within the drive's input voltage rating range.
oL1	Internal electronic overload trip	<ol style="list-style-type: none"> 1. Check for a possible motor overload. 2. Check electronic thermal overload setting. 3. Increase motor capacity. 4. Reduce the current level so the drive's output current does not exceed the value set by the Motor Rated Current, parameter 7-00.
EF	External terminal EF-GND goes from OFF to ON	When the EF-GND is closed, the output will be turned off (under N.O.E.F.)

Common Problems and Solutions, continued

Fault Name	Fault Description	Corrective Action
oL2	Motor overload	<ol style="list-style-type: none"> 1. Check settings for parameters 6-03 to 6-05. 2. Reduce the motor load. 3. Adjust the over-torque detection setting to an appropriate setting.
ocA	Over-current during acceleration: <ul style="list-style-type: none"> • Short circuit at motor output • Torque boost too high • Acceleration time too short • Drive's output capacity too small 	<ol style="list-style-type: none"> 1. Make sure the insulation is adequate at the output line. 2. Decrease the torque boost setting in parameter 7-02. 3. Increase the acceleration time. 4. Replace the drive with one that has a higher output capacity (next level hp).
ocd	Over-current during deceleration: <ul style="list-style-type: none"> • Short circuit at motor output • Deceleration time too short • Drive's output capacity too small 	<ol style="list-style-type: none"> 1. Make sure the insulation is adequate at the output line. 2. Increase the deceleration time. 3. Replace the drive with one that has a higher output capacity (next level hp).
ocn	Over-current during steady-state operation: <ul style="list-style-type: none"> • Short circuit at motor output • Sudden increase in motor loading • Drive's output capacity too small 	<ol style="list-style-type: none"> 1. Make sure the insulation is adequate at the output line. 2. Check for possible motor stall. 3. Replace the drive with one that has a higher output capacity (next level hp).
cF1	Internal memory IC cannot be programmed	<ol style="list-style-type: none"> 1. Switch off power supply. 2. Make sure the input voltage falls within the drive's input voltage rating range. 3. Switch on the drive.
cF2	Internal memory IC cannot be read	<ol style="list-style-type: none"> 1. Check the connections between the main control board and the power board. 2. Reset drive to factory defaults.
cF3	Drive's internal circuitry abnormal	<ol style="list-style-type: none"> 1. Switch off power supply. 2. Make sure the input voltage falls within the drive's input voltage rating range. 3. Switch on the drive.
HPF	Hardware protection failure	Consult Eaton.
codE	Software protection failure	Consult Eaton.
cFA	Auto acceleration/deceleration failure	Do not use the auto accel./decel. function.
CE1	Communication error	<ol style="list-style-type: none"> 1. Check the connection between the drive and computer for loose wires. 2. Make sure the communication protocol is properly set.
bb	External base block (When the external input terminal (BB) is active, the drive output will be turned off.)	Disable the connection between external input terminal (BB) and the drive. The drive will begin to run again.
oL	Drive detects excessive drive output current	<ol style="list-style-type: none"> 1. Check whether the motor is overloaded. 2. Reduce torque compensation setting set in parameter 7-02. 3. Increase the drive's output capacity. <p>Note: The drive can withstand up to 150% of the rated current for a maximum of 60 seconds.</p>

Eaton Electrical Inc.
 1000 Cherrington Parkway
 Moon Township, PA 15108-4312
 USA
 tel: 1-800-525-2000
www.EatonElectrical.com



Cutler-Hammer

© 2006 Eaton Corporation
 All Rights Reserved
 Publication No. MN04001003E/CPG
 February 2006