

Electraflash® Strobe Warning Light

Model 141ST



DESIGNED FOR INDUSTRIAL OR VEHICULAR USE

- Available in 12VDC, 24VDC, 120VAC and 240VAC
- Four dome colors
- 4,000 hour strobe tube
- Surface mount or integrated 1/2-inch pipe mount
- UL Listed and CSA Pending for indoor/outdoor use
- Type 3R enclosure

Federal Signal's Electraflash® 141ST is an economical strobe light designed for a variety of industrial uses. This compact warning light is less than six inches tall and six inches in diameter. Models are available in four fresnel dome colors, including amber, blue, green and red. All models are UL Listed for indoor/outdoor use and the 120VAC models are CSA Certified.

The Model 141ST is available in 12VDC, 24VDC, 120VAC and 240VAC and includes a removable strobe mechanism. The 12VDC and 24VDC units have three holes for flat surface mounting. The 120VAC and 240VAC versions come ready to mount on a 1/2-inch pipe. Optional wall mounting brackets (Model LWMB2) or corner mounting brackets (Model LCMB2) are available for the 120VAC and 240VAC units.

Federal Signal's Electraflash strobe lights are designed for both indoor and outdoor industrial environments. The unit's convenient size and intense light output make it ideal for use on maintenance vehicles, fork lifts, and other material handling equipment. The economical Model 141ST effectively alerts of hazardous conditions or dangerous areas.

Federal Signal's Electraflash strobe warning light is an affordable visual signal which is ideally suited for light duty applications.

Model	Voltage	Operating Current	Flash Rate/Minute	Peak ¹ Candlepower	Mount
141ST	12VDC	0.18 amps	80	100,000	Surface
141ST	24VDC	0.08 amps	80	100,000	Surface
141ST	120VAC 50/60HZ	0.06 amps	80	100,000	1/2" Pipe
141ST	240VAC 50/60HZ	0.03 amps	80	100,000	1/2" Pipe

¹ Peak candlepower is the maximum light intensity generated by a flashing light during its light pulse



ELECTRAFLASH® STROBE LIGHT (141ST)

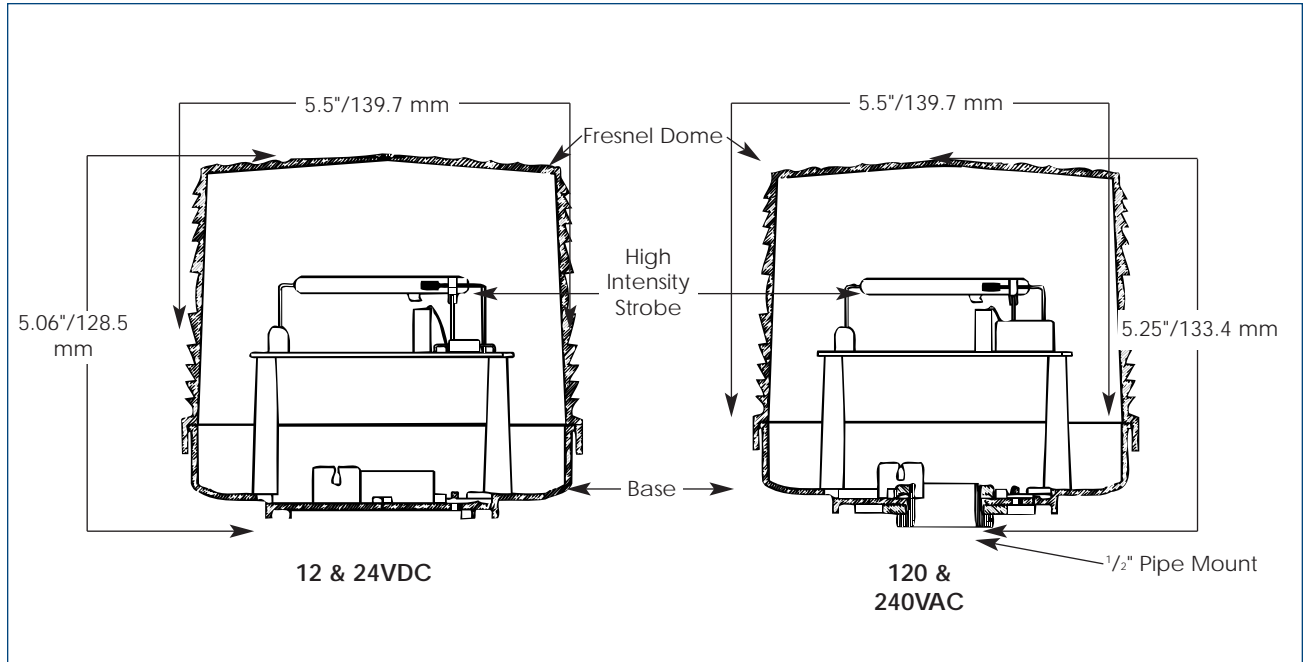

SPECIFICATIONS

Lamp Life*:	4,000 hours	4,000 hours
Lamp Style:	Strobe	Strobe
Operating Temperature:	-31°F to 150°F	-35°C to 66°C
Net Weight:		
DC Models	0.8 lbs.	0.4 kg
AC Models	0.9 lbs.	0.4 kg
Shipping Weight:		
DC Models	1.1 lbs.	0.5 kg
AC Models	1.2 lbs.	0.5 kg
Height:		
DC Models	5.06"	128.5 mm
AC Models	5.25"	133.4 mm
Diameter:		
DC Models	5.50"	139.7 mm
AC Models	5.50"	139.7 mm

* Optimal hours under ideal conditions.

HOW TO ORDER

- Specify model, voltage and color
- Specify options (120VAC and 240VAC only):
 Corner Bracket (LCMB2)
 Wall Bracket (LWMB2)
- Please refer to Model Number Index 141ST beginning on page 376

REPLACEMENT PARTS

<u>Description</u>	<u>Part Number</u>	<u>Description</u>	<u>Part Number</u>
Dome, Amber	K8263079A	PC Assembly, 24VDC	K2001201B-01
Dome, Blue	K8263079A-01	PC Assembly, 120VAC	K2001195D
Dome, Green	K8263079A-03	PC Assembly, 240VAC	K2001195D-01
Dome, Red	K8263079A-02	Strobe Tube	K149128A
PC Assembly, 12VDC	K2001201B	Pipe Mount Kit	K8263093A