

TECHNICAL DATA

TYPICAL APPLICATIONS

- Used with Low Voltage Sensors
- Multiple Sensors
- Multiple Loads

POWER PACK HIGHLIGHTS

- Dual Voltage Transformer
- Self-Contained Relay
- Powers up to 14 sensors

SPECIFICATIONS

- Size: (1/2" inch chase nipple not inc.)
MP-20 & MSP-20: 2 1/4" x 3" x 1 7/8"
- Mounting: 1/2" inch chase nipple
- Operating Voltage: 120, 240, or 277 VAC
- Each Relay: 20 Amps
- 1 HP Motor Load
- Output Voltage: 15 VDC, 150 mA
- Class II: 18 AWG, up to 2,000 ft.
- Plenum Rated
- Relative Humidity: 20 to 90% non-condensing
- Operating Temp: 14° to 160° F
- Storage Temp: -14° to 160° F
- UL and CUL Listed
- 5 Year Warranty
- Made in U.S.A.

LOW TEMP/HI HUMIDITY(-LT)

- Conformally Coated PCB
- Operates down to -40° F
- Corrosion resistant from moisture

PLENUM CONSIDERATIONS

Most local codes allow for small plastic controls in Return Air Plenums; *Some Do Not!* To meet local code, the Power Pack can be mounted inside an adjacent (Deep) junction box as shown below.

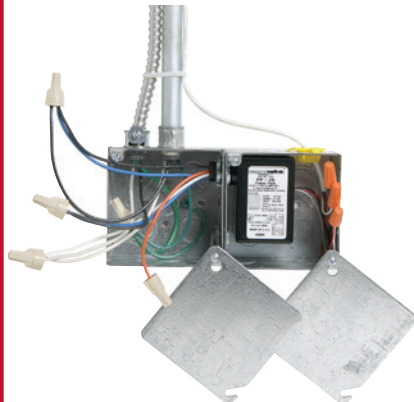

MP-20 MSP-20



Plenum Rated

Mini Power Packs are the heart of the Low Voltage Sensor System. The MP-20 transforms 120, 240 or 277 Volts to class II 15 VDC to power the remote sensors. Although Plenum Rated, the elongated mounting nipple allows for the MP-20 to be mounted either directly thru a 1/2" inch knockout in a junction box, or to be located inside an adjacent box for specific local code requirements. Up to 14 sensors may be connected to one MP-20. Multi-circuit control can be handled by multiple MP-20's and Slave Packs (MSP-20) may be configured. MP-20's can be wired continuously hot (line side), or on the switch leg (load side) without nuisance delays upon turn "On".

MINI POWER PACK OPERATION

The Mini Power Pack consists of a transformer and a relay. The transformer has a dual primary high voltage input, accepting 120, 240, or 277 VAC. The secondary voltage provides power to Sensor Switch low voltage heads. When the sensor head detects motion, they electronically signal the power pack to close the relay(s) connected to the lighting system.

LOW VOLTAGE OPERATION AND TEST

The Low Voltage Wires are color coded Red (15 VDC), Black (Common), and White (Occupancy Signal). With no sensors connected, touch the Red wire to the White. The lights should turn "On". Remove the connection and the lights should turn "Off". With the sensors connected, the Red and Black wires provide DC power to the remote sensors, and when there is occupancy detected, the White wire produces a 15 VDC signal from the sensor to the power pack initiating the lights to "On". Upon initial power up, the Sensors automatically send an "On" signal until the sensors have stabilized and "Timed Out".

SIZING OF THE SYSTEM - VARIOUS COMBINATIONS

Combining Power Packs provides for additional power to drive remote devices. Maximum numbers of remote sensors are shown below based on the Power Pack/ Slave Pack being used: *Maximum number of "Relays" is 30.*

	Sensors	Sensors with Relay
1 MP-20	14	8
1 MP-20 w/MSP-20	7	6
2 MP-20	28	16

Note 1: Only three relays may be controlled with one Mini Power Pack. If more than three circuits are required, multiple MiniPower Packs must be used.

Note 2: Only one "Sensor with Relay" is required in most cases. See Technical Data on Low Voltage Sensors and SPDT EMS Interface Option.

SYSTEMS CONSIDERATIONS

The local override switch may be upstream or downstream of an MP-20. However, if an MSP-20 Auxiliary Relay controller is being used, the switch(es) should be downstream on the load side of the relay. If power is disconnected to the Power Pack all subsequent relays will open, turning off all of the loads. If wiring the local switches before the Power Pack and Slave Pack, use multiple MP-20's, one for each circuit. This will allow for one circuit to remain powered, keeping the system operational when the other is turned off. When controlling a dimming circuit, MP-20 must be wired before dimmer, or MSP-20 may be wired after dimmer.

CATALOG INFORMATION

MODEL#	DESCRIPTION	OUTPUT VOLTAGE	OUTPUT CURRENT
MP-20	Power Pack with 20 Amp Relays	15 to 24 VDC	70 to 110 mA
MSP-20	Slave Pack with 20 Amp Relays	N/A	40 mA(consumption)

**Add suffix -LT for Low Temp/Hi Humidity

T053-001

TYPICAL WIRING DIAGRAMS - DO NOT WIRE HOT

NOTE: The Power Pack must be connected to a single phase Hot and Neutral System. For 120 VAC, connect the Black wire to Hot, White wire to Neutral, and Cap off the Orange wire. For 240-277 VAC, connect the Orange to Hot, White to Neutral, and Cap off the Black wire. *Never connect both the Black and Orange wires!* Low Voltage wire can be 18 to 22 AWG; shielding is not necessary.

Multiple Sensors Controlling One Circuit

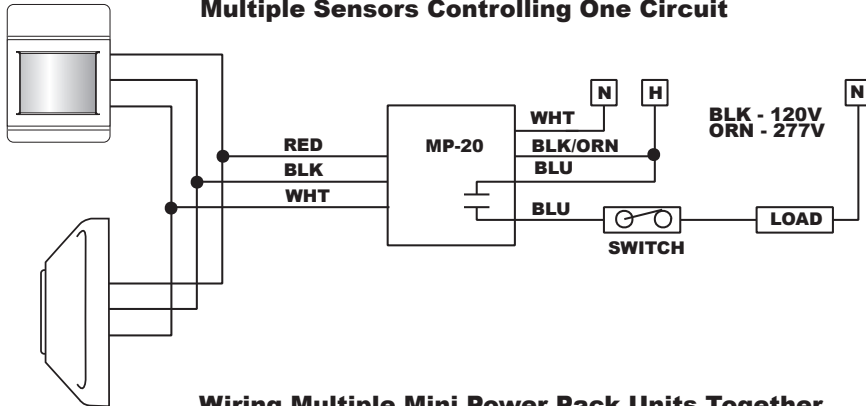

Wiring Multiple Mini Power Pack Units Together

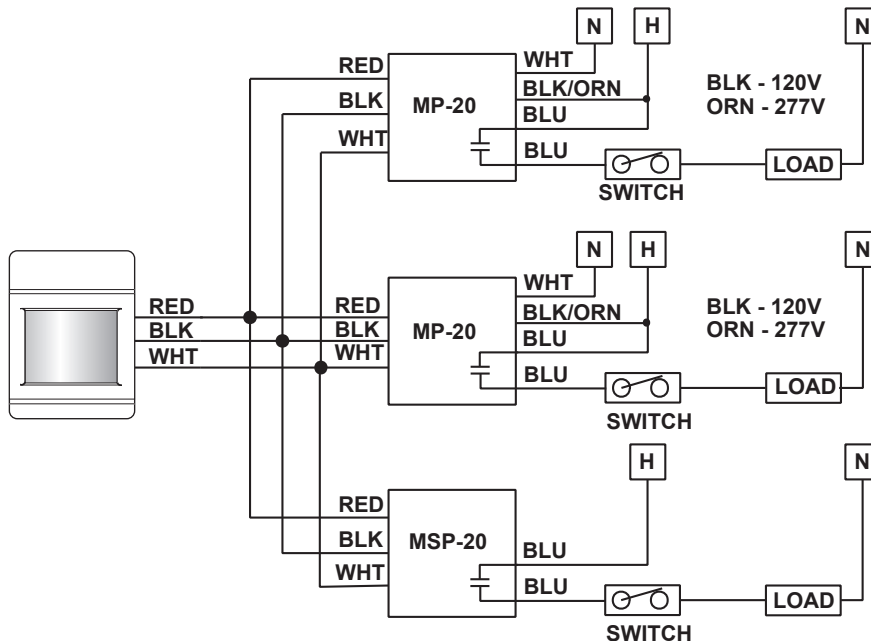

One Sensor Controlling One Circuit

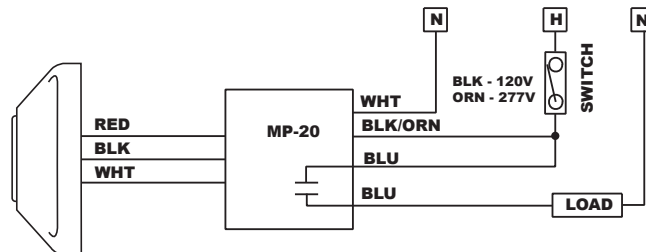

WARRANTY: Sensor Switch, Inc. warrants these products to be free of defects in manufacture and workmanship for a period of sixty months. Sensor Switch, Inc., upon prompt notice of such defect will, at its option, provide a Returned Material Authorization number and a replacement product.
LIMITATIONS AND EXCLUSIONS: This Warranty is in full lieu of all other representation and expressed and implied warranties (including the implied warranties of merchantability and fitness for use) and under no circumstances shall Sensor Switch, Inc. be liable for any incidental or consequential property damages or losses.



SENSOR SWITCH, INC.
 900 Northrop Rd., Wallingford, CT 06492
 (203) 265-2842 info@sensorswitch.com
 www.sensorswitch.com

revised 7/8/2005
 copyright Sensor Switch, Inc. 2005