

ASSEMBLY INSTRUCTIONS FOR GATE VALVE LOCK-OUT

Figure A

- 1.) Close valve and verify energy is isolated
- 2.) Cover valve handle with PSL-V lockout of corresponding size.

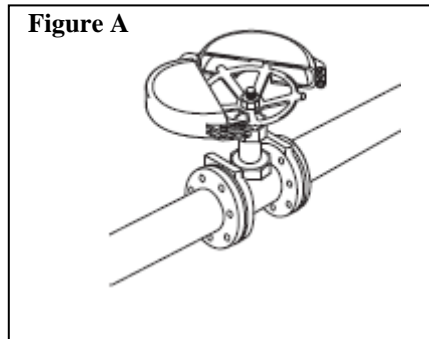

ASSEMBLY INSTRUCTIONS FOR GATE VALVE LOCK-OUT

Figure A

- 1.) Close valve and verify energy is isolated
- 2.) Cover valve handle with PSL-V lockout of corresponding size.

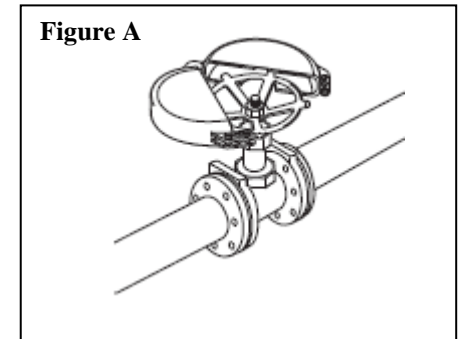

Figure B

- 1.) Close PSL-V lockout and install lock.

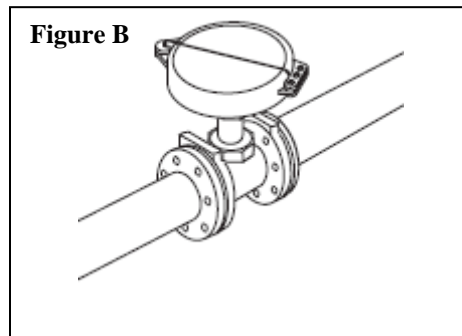

Figure B

- 1.) Close PSL-V lockout and install lock.

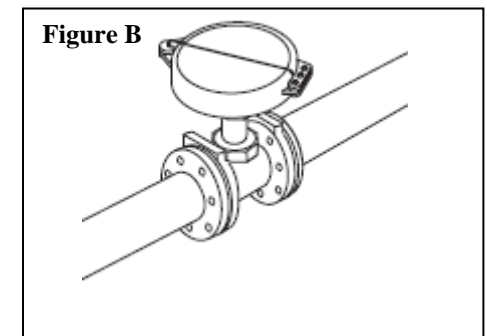

Figure C

- 1.) If needed, cut the recessed section with a knife to make clearance for the valve stem.

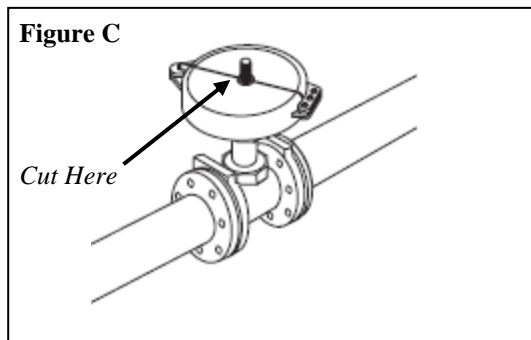

Figure C

- 1.) If needed, cut the recessed section with a knife to make clearance for the valve stem.

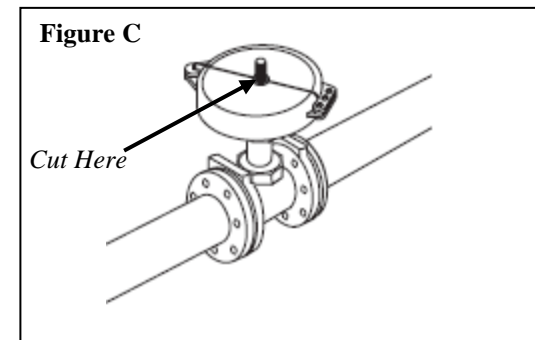

Figure D

- 1.) For small valves using PSL-V2A Only
- 2.) Drill a hole aligned with hole created as in Figure C
- 3.) Close the lockout completely and install lock

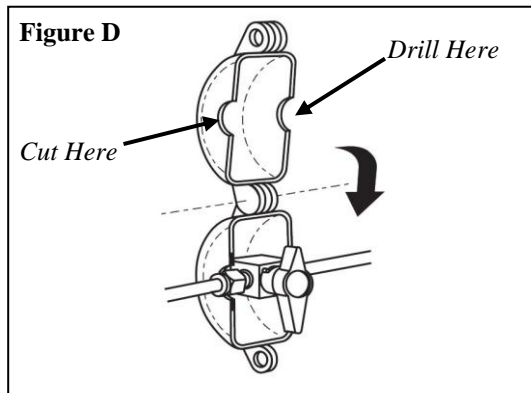
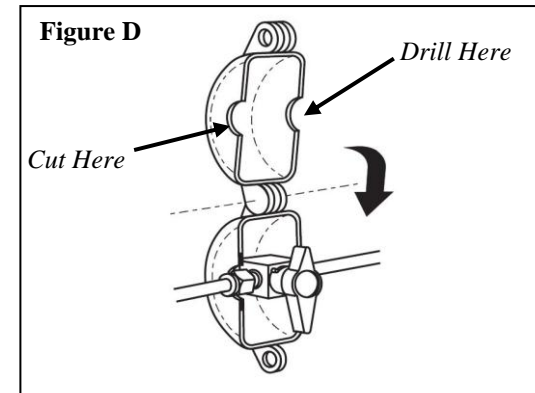

Figure D

- 1.) For small valves using PSL-V2A Only
- 2.) Drill a hole aligned with hole created as in Figure C
- 3.) Close the lockout completely and install lock



PANDUIT[®]

For more information
Visit us at www.Panduit.com
Contact Customer Service by email: cs@panduit.com
Or by phone: 800-777-3300

PANDUIT[®]

For more information
Visit us at www.Panduit.com
Contact Customer Service by email: cs@panduit.com
Or by phone: 800-777-3300