

Instructions for Advantage Control Modules Used with Full Voltage Non-Reversing Advantage Motor Starters & Contactors

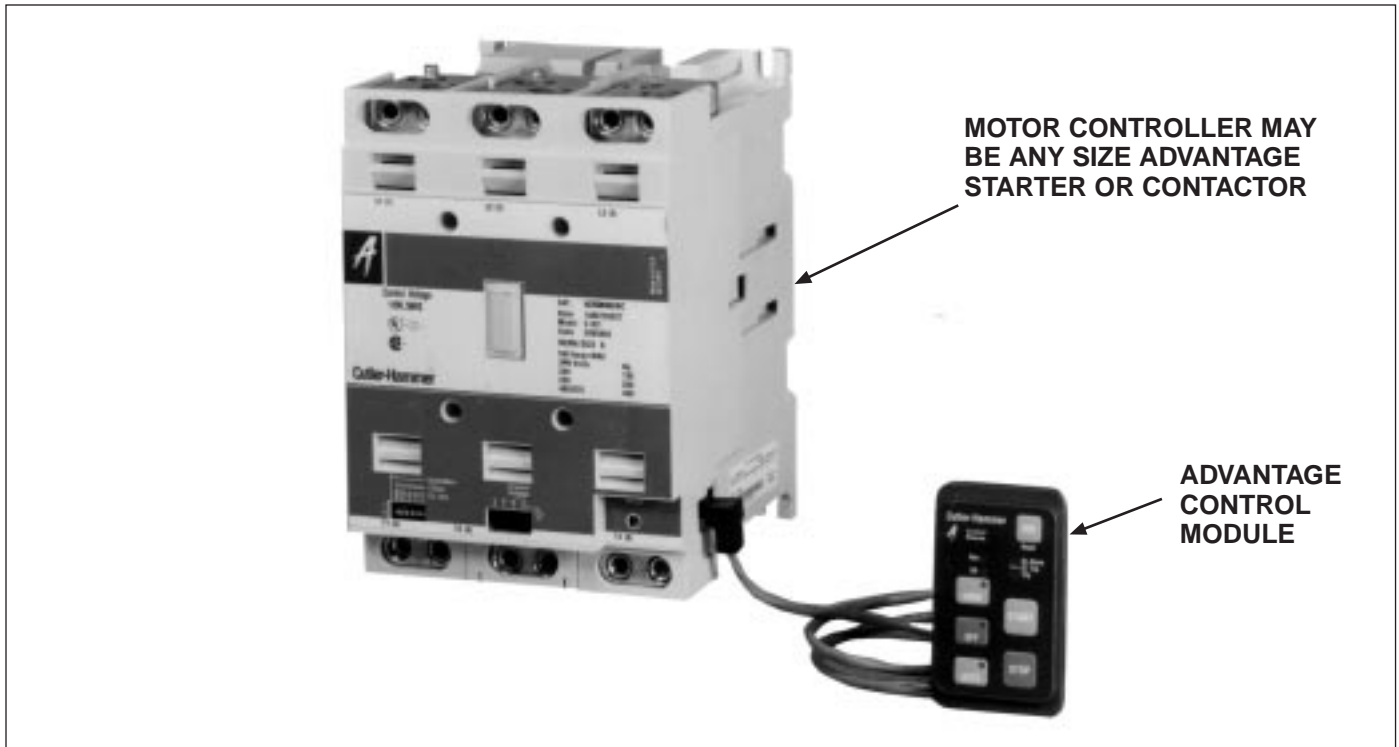

Fig. 1 ACM Connection to Advantage Motor Starter

ADVANTAGE CONTROL MODULES

The four full voltage non-reversing (FVNR) Advantage Control Modules (ACM's) listed in Table I are designed to be connected to Advantage motor controllers and replace discrete pushbuttons, indicating lights, and external resets.

TABLE I - ADVANTAGE CONTROL MODULES		
Catalog Number	ACM Type *	Operators Included
WPBFV1	Status Only	Reset Only
WPBFV2	Start/Stop	2PBs + Reset
WPBFV3	Start/Stop with Hand/Off/Auto	2PBs + Reset + Selector Switch
WPBFV4	On/Off/Auto	3 Choice Selector Switch + Reset

* All include four LED's to indicate status

Each of the ACM's has Run, Off, Overload Alarm, and Trip status indicators in the form of light emitting diodes (LED's) as follows:

LED	Color	Starter Status
Run	Red	On, contactor closed
Off	Green	Off, controller open
Overload Alarm	Red (blinking)	Thermal Overload Alarm Condition
Trip	Red	Tripped due to Ground Fault, Phase Loss, or Phase Imbalance
OL Trip*	Red	Overload Trip

* Both the Overload Alarm and Trip LED's will be on when an Overload Trip condition is present.

The operation of all front panel LED's can be checked at any time by pressing the RESET membrane pushbutton. All LED's will remain lit as long as the RESET button is pressed.

The primary function of the reset membrane pushbutton is to reset trip conditions (overload, phase, or ground).

DEFINITIONS

IMPACC - The Cutler-Hammer communications system which includes computer interface cards, WPONI modules, INCOM network, Advantage motor controllers, twisted wire, IQ products, etc.

INCOM - The network that is part of the IMPACC system

ADVANTAGE MOTOR CONTROLLERS - Advantage contactors and starters

MODE - Method of control, e.g., hand (manual) or automatic, or status (ON, OFF)

ACM - Advantage Control Module

FVNR - Full Voltage Non-Reversing

INSTALLATION

This device is designed to be installed, operated, and maintained by adequately trained workmen. These instructions do not cover all details, variations, or combinations of the equipment, its storage, delivery, installation, checkout, safe operation, or maintenance. Care must be exercised to comply with local state, and national regulations, as well as safety practices, for this class of equipment.

Use Greenlee punch and die set, Greenlee #50600710, or utility tools to create the 2.25 x 3.50 inch opening in sheet metal ranging from .060 to .090 inch in thickness. The mounting holes shown in Figure 2 are not needed for Type 1 enclosures where the snap-in feature provided is sufficient for mounting. For Type 12 enclosures, drill the two .180" diameter holes and use two #8 screw/washer /nut combinations to impress the gasket provided.

Read the full load current from the motor nameplate and set the overload protection appropriate for the motor, taking into account the motor service factor (S.F.).

Determine the quantity and appropriate length of interconnect cables needed to connect the ACM to the Advantage motor controller (contactor or starter). See Table II. Insert the straight end of the interconnect cable into the connected labeled "ADVANTAGE STARTER" on the back of the ACM. Be sure to line up the blank position in the cable connector with the missing pin on the ACM internal connector. Take the right angle end of the interconnect cable and insert it into the front 5 pins in the device cable connector receptacle on the side of the Advantage motor controller. Be sure to line up the blank position in the cable connector with the missing pin in the device connector receptacle. Expect the shock mounted printed circuit board inside the device to give under pressure of insertion. If remote inputs are used, wire the units per the provided figures. If an Advantage

communications module (WPONI) is used, connect the WPONI cable to the open connection on the back of the ACM labeled "WPONI/METERING UNIT". See Figure 3.

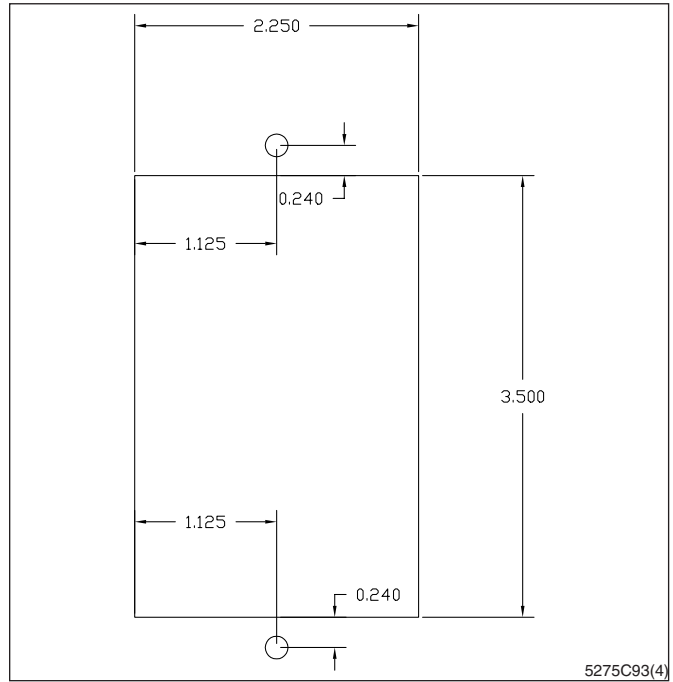

Fig. 2 Panel Cutout Dimensions (dimensions in inches)

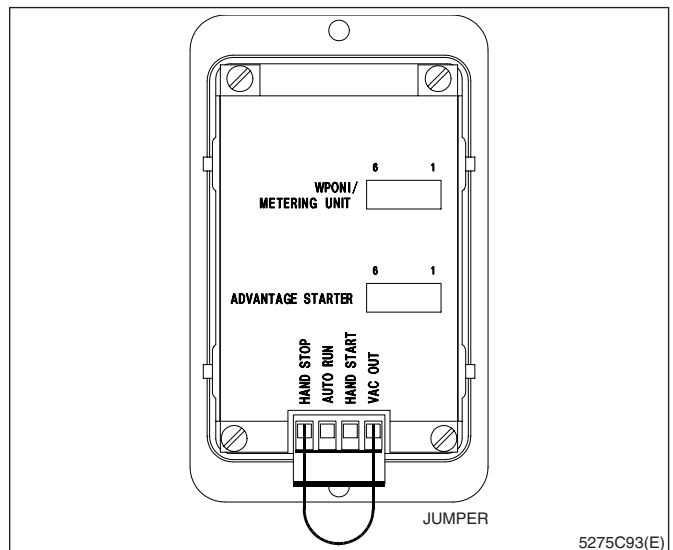

Fig. 3 Rear View of an ACM

TABLE II - INTERCONNECT CABLES	
Catalog Number	Description
WACM1	1 Foot Interconnect Cable
WACM3	3 Foot Interconnect Cable
WACM6	6 Foot Interconnect Cable
WACM10	10 Foot Interconnect Cable



Fig. 4 Type WPBFV1



Fig. 5 Type WPBFV2

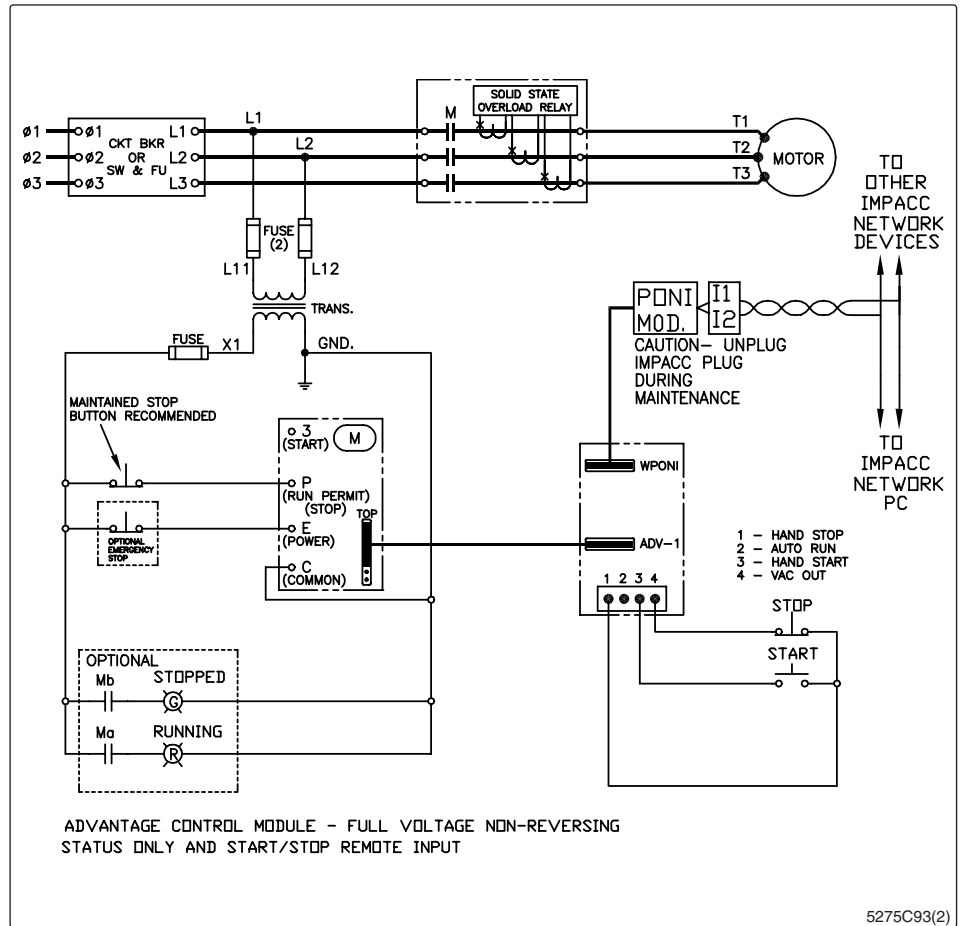

Fig. 6 Type WPBFV1 and WPBFV2 Connection Diagram

CAUTION

REMOVE POWER FROM (DEENERGIZE) THE DEVICE TO WHICH THE ACM IS BEING ATTACHED OR WIRED, OR DAMAGE WILL RESULT.

DO NOT CONNECT ANY EXTERNAL 120VAC SOURCE TO THE REMOTE INPUT TERMINAL LABELED "VAC OUT" ON THE BACK OF AN ACM. SEE FIGURE 3. ALSO, DO NOT CONNECT ANY EXTERNAL LOADS (PILOT LIGHTS, RELAYS, ETC.) TO THE TERMINAL LABELED "VAC OUT". THIS IS A TERMINAL TO BE USED ONLY FOR THE WIRING OF THE REMOTE CONTROL DEVICES PER FIGURES 6, 8, AND 10.

ACM TYPE WPBFV1

The Type WPBFV1 ACM provides status only. It has no front panel control capability other than reset. See Figure 4. This ACM can only be used to monitor the operational status of the Advantage motor controller from the front

panel of the unit. In order to control the Advantage motor controller, remote FORWARD/REVERSE/STOP pushbuttons must be used and the remote input terminals on the rear of the ACM must be wired according to Figure 6. Remove the jumper installed between HAND STOP and VAC OUT. See Figure 3. The motor controller cannot be controlled over the INCOM network, but can be monitored as long as an ACM is connected to an Advantage motor controller from the 3PEC terminals. The 3PEC terminals can only be used to stop the starter.

ACM TYPE WPBFV2

The Type WPBFV2 ACM can be used to monitor the Advantage motor controller operational status and control the starter (starting and stopping) from the front panel FORWARD (FWD)/REVERSE (REV)/STOP membrane pushbuttons. See Figure 5. Control of the starter or contactor can also be implemented via the remote input terminals on the back of the ACM. See Figure 3. This type ACM cannot be controlled with the IMPACC system. If the remote inputs are not connected per Figure 6, a



Fig. 7 Type WPBFV4

jumper must be connected between VAC OUT and HAND STOP in order to control the starter from the front panel FWD/REV/STOP membrane pushbuttons. See Figure 3. This jumper is installed at the factory. As long as an ACM is connected to an Advantage motor controller, the user cannot start the Advantage motor controller from the 3PEC terminals. The 3PEC terminals can only be used to stop the starter.

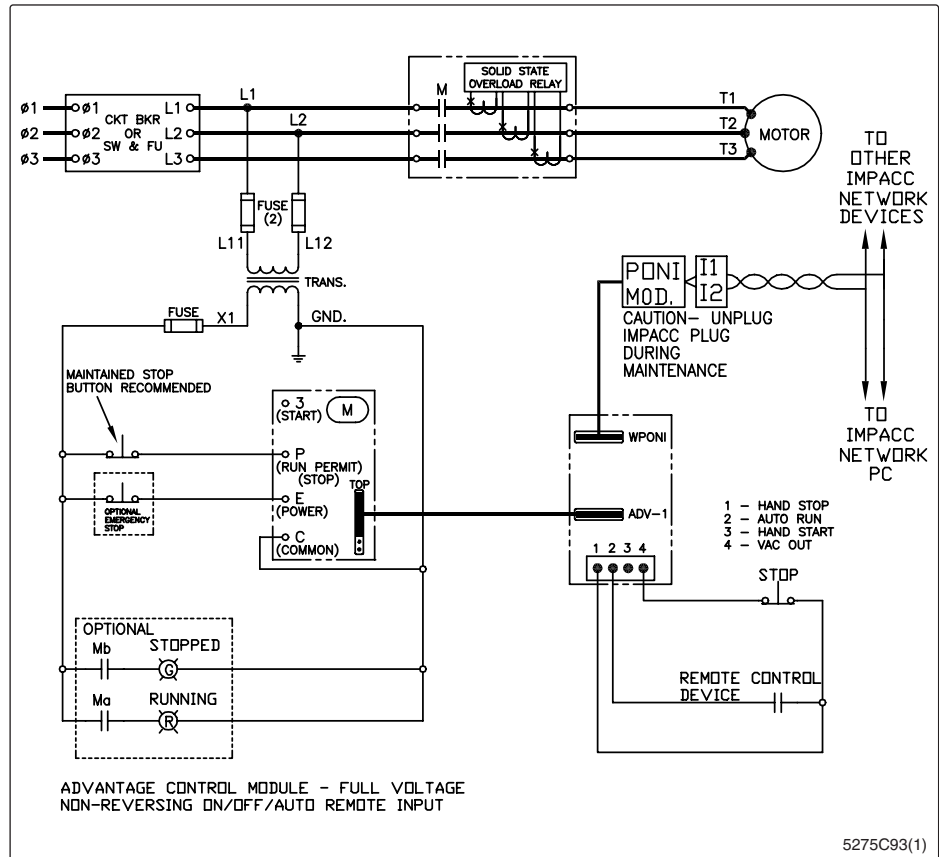

Fig. 8 Type WPBFV4 Connection Diagram

ACM TYPE WPBFV4

The Type WPBFV4 ACM (Figure 8) can be used to monitor the operational status of the Advantage motor controller and control the unit from the front panel ON/OFF membrane pushbuttons. **THIS TYPE ACM SHOULD ONLY BE USED WHERE THE MOTOR RESTARTING AUTOMATICALLY AFTER A POWER LOSS DOES NOT CREATE A SAFETY HAZARD.**

With this version, the remote hand inputs HAND START and HAND STOP on the back side of the ACM cannot be utilized. The only input that can be utilized is the AUTO RUN input (see Figure 8) as long as the unit is set in the automatic mode via the front panel AUTO membrane pushbutton. This ACM can be controlled by the IMPACC system as long as the ACM is set in the AUTO mode. A jumper must be connected between VAC OUT and HAND STOP (see Figure 3) in order to control the starter from the front panel ON/OFF membrane pushbuttons and over the IMPACC system using an Advantage WPONI module. This jumper is installed at the factory. As long as an ACM is connected to an Advantage motor controller, the user cannot start the Advantage motor controller from the 3PEC terminals. The 3PEC terminals can only be used to stop the starter.

If AUTO mode is selected, control can be implemented by either the remote AUTO RUN input or the IMPACC system.

NOTE: If there is a jumper placed between VAC OUT and HAND START, the **WPBFV4** version of the ACM becomes a “LOCK ON” device. If the unit is in the ON mode (starter closed) when the Advantage motor controller loses power, the following events will happen when the starter regains power; 1) the ACM will power up in the OFF mode while it establishes communication with the starter, and 2) after communications are established, the ACM will return to the ON mode and thus close the starter as long as no lockout or trip conditions are present. There is no way to tell which mode the ACM is in while it is powered down.

If the unit is in the AUTO mode when the Advantage motor controller loses power, the following events will occur when the starter regains power:

1. The ACM will power up in the OFF mode while it establishes communication with the starter.
2. The ACM will return to the AUTO mode and control is allowed via IMPACC or the AUTO RUN terminal input.

If there is no jumper between VAC OUT and HAND START and if the ACM was in the ON mode when the starter lost power, when the starter regains power the ACM will default to the OFF mode.



Fig. 9 Type WPBFV3

ACM TYPE WPBFV3

The Type WPBFV3 ACM (Figure 9) can be used to monitor the operational status of the Advantage motor controller and provide full control (HAND, AUTO, and IMPACC) of the controller. In order to control the Advantage starter with the IMPACC system, the ACM must first be put in the AUTO mode. If the ACM is in either the OFF or HAND mode, control over the INCOM network will not be allowed. Monitoring is available in all modes. In order to control the unit with either the front panel START/STOP membrane pushbuttons or the remote pushbuttons, the ACM must be first placed in the HAND mode. In order to control the unit with remote AUTO RUN or input, the ACM must first be placed in the AUTO mode. See Figure 10 for remote control device wiring details.

If the remote pushbuttons are not connected per Figure 10, a jumper must be connected between terminals VAC OUT and HAND STOP (see Figure 3) in order to control the starter from the front panel HAND/START/STOP membrane pushbuttons or with the IMPACC system. As long as an ACM is connected to an Advantage motor controller, the user cannot start the Advantage motor controller from the 3PEC terminals. The 3PEC terminals can only be used to stop the starter.

If AUTO mode is selected, control can be implemented by either the remote AUTO inputs (remote control devices) or the IMPACC system.



CAUTION

IF THE AUTO RUN INPUT IS ACTIVE, PRESSING THE FRONT PANEL KEY SEQUENCE OFF-AUTO-OFF OR OFF-HAND-OFF FASTER THAN 1.5 SECONDS BETWEEN KEY PRESSES MAY RESULT IN THE ACM ENTERING AN INCORRECT MODE ON POWER CYCLE.

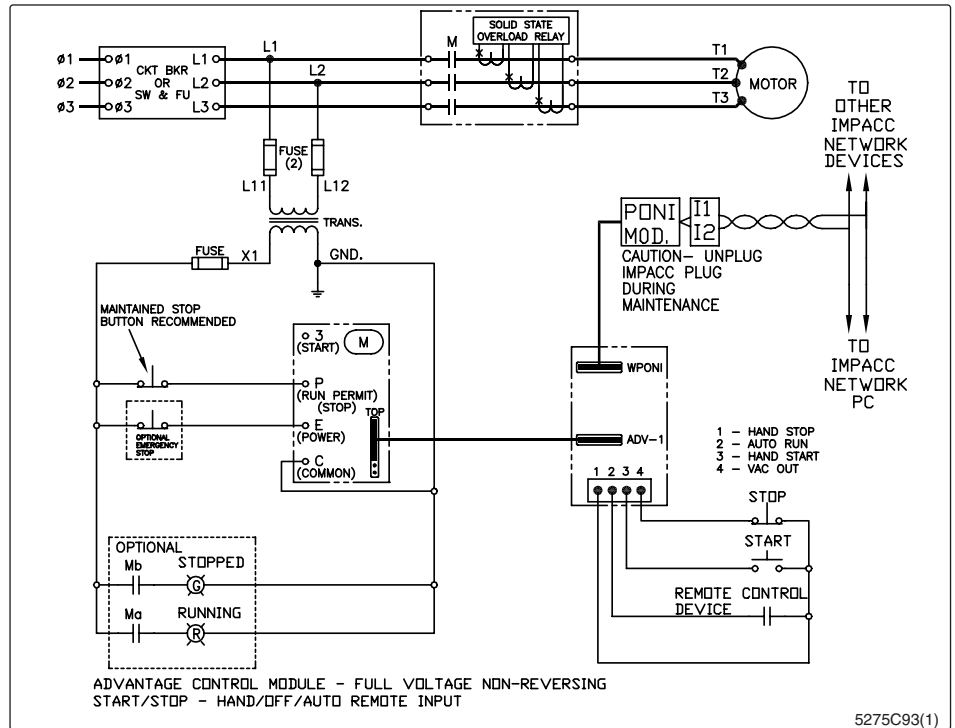

Fig. 10 Type WPBFV3 Connection Diagram

EMERGENCY STOP

The optional EMERGENCY STOP pushbutton shown in Figures 6, 8, and 10 provides a faster stop (by approximately 1/10 of a second) by bypassing the distributed opening sequence provided when the normal STOP pushbutton is operated. The built-in distributed opening sequence insures that each set of contacts associated with a phase takes its share of the wear associated with opening the circuit first and the ease of opening last, to provide uniform wear on all contacts and provide longer life for a given set of contacts, i.e., all three phases wear at the same rate.

OPERATIONAL CHECK

When an ACM is first powered up, the top two rows of LED's (RUN, OFF, ALARM, and TRIP) will blink, while the ACM is establishing communications with the Advantage motor controller. If after approximately two seconds the LED's do not stop blinking, there is a communication problem between the ACM and the Advantage motor controller. After communication is established, the ACM will then display the status of the Advantage motor controller. Also, the ACM will default to the mode of operation it was in before power was removed (HAND, OFF, or AUTO). In order to tell which mode of operation the ACM is in, observe the LED's in the upper left-hand corners of the HAND/OFF/AUTO membrane pushbuttons. The ACM can only be in one mode at a time.

The status of the Advantage motor controller can be monitored by observing the top two rows of LED's on the ACM. See Page 1.

TROUBLESHOOTING HINTS

Problem:

Top two rows of LED's continue to alternate blinking after the unit is first powered up.

Cause:

- Interconnect cable plugged into wrong port on rear of ACM.
- Bad interconnect cable.
- Bad ACM or Advantage motor controller.

Solution:

- Move interconnect cable from port labeled WPONI to port labeled ADVANTAGE STARTER.
- Replace interconnect cable.
- Replace defective component.

Problem:

Cannot start the Advantage motor controller from front panel membrane pushbuttons or remote inputs.

Cause:

- There is no jumper between VAC OUT, and HAND STOP.
- Terminal P is not energized on the Advantage motor controller.
- If remote inputs are used, they are not wired per Figures 6, 8, or 10.

Solution:

- Add a jumper between VAC OUT and HAND STOP.
- Energize the P terminal on the Advantage motor controller.
- Correct the remote input wiring per Figure 6, 8, or 10, depending on which version of the ACM is being used.

ACM SPECIFICATIONS

Input Supply Requirements

120VAC (supplied by the Advantage motor controller)

Maximum Distance from Advantage Motor Controller
10 Feet

Operating Frequency
50 or 60 HZ

Operating Temperature
-20 to 70°C

Storage Temperature
-20 to 85°C

Humidity
0 to 95% (non-condensing)

Remote Input Wire Size
#18 - #14 AWG

Maximum Distance Between Remote
Pushbuttons and ACM
200 Feet

Terminal Input Control Voltages
ON: > 30VAC
OFF: < 10VAC

Cutout Dimensions
2-1/4 x 3-1/2 inches (see Figure 2)
The cutout can be made using a Greenlee
rectangular punch #50600710

Enclosure Type
1 or 12 when properly installed



CAUTION

FAILURE TO COMPLETELY DISCONNECT THE MOTOR CONTROLLER FROM ALL COMMUNICATION NETWORKS AND POWER SOURCES, INCLUDING CONTROL CIRCUIT POWER, PRIOR TO INSPECTION MAY RESULT IN SEVERE INJURY OR DEATH

CUTLER-HAMMER

4201 North 27th Street
Milwaukee, WI 53216