

Instruction Leaflet for S701 Soft Starters

Description

The S701 device is a reduced voltage soft start series controller designed to control acceleration and deceleration of three-phase motors. The S701 provides the user the ability to adjust initial torque, ramp up and down time, and also select kick start for high inertia loads.

Approvals

CAN. CSA-C22.2 / UL Std. No. 508

IEC 947-4-2, IEC 158-2,

EN 60947-4-2, HD 419.2-S1

CE Marked

Mounting Guidelines

Important — The **S701_15**, and **S701_25** controllers are designed for vertical mounting in free air. If these controllers are mounted horizontally, the load current must be reduced to 50% of rated current.

WARNING

DO NOT INSTALL OR PERFORM MAINTENANCE ON THIS DEVICE WHILE EQUIPMENT IS ENERGIZED. DEATH OR SEVERE PERSONAL INJURY CAN RESULT FROM CONTACT WITH ENERGIZED EQUIPMENT. VERIFY THAT NO VOLTAGE IS PRESENT BEFORE PROCEEDING WITH INSTALLATION OR MAINTENANCE.

Only qualified persons, as defined in the National Electric Code, who are familiar with the installation, maintenance and operation of this device and the equipment onto which it is to be installed, as well as applicable local, state and national regulations and industry standards and accepted practices regarding safety of personnel and the equipment safety should be permitted to install, maintain or operate this device. These instructions are provided only as a general guide to such qualified persons and are not all-inclusive. They do not cover every application or circumstance which may arise in the installation, maintenance or operation of this equipment. Users are advised to comply with all local, state and national regulations and industry standards and accepted practices regarding safety of personnel and equipment.

CAUTION

REMOVE ALL POWER FROM THE INSTALLATION BEFORE ATTEMPTING TO INSTALL OR REMOVE THIS DEVICE. THIS INCLUDES L1, L2, L3 AS WELL AS A1, A2, 11 AND 12.

Dimensions, mm [inches]

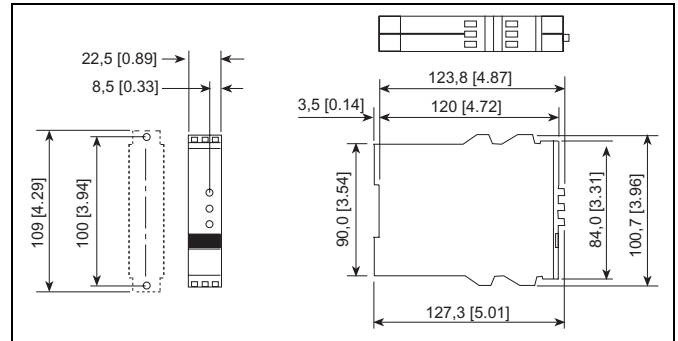

Figure 1. Approx. Dimensions in mm [inches] — S701_03

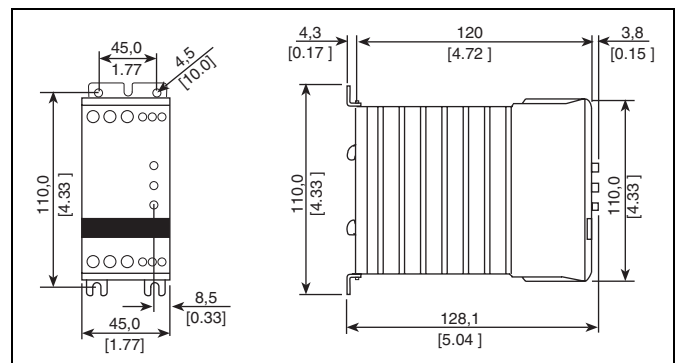

Figure 2. Approx. Dimensions in mm [inches] — S701_15

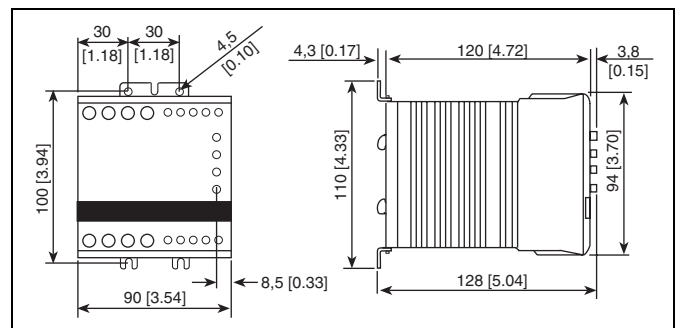

Figure 3. Approx. Dimensions in mm [inches] — S701_25

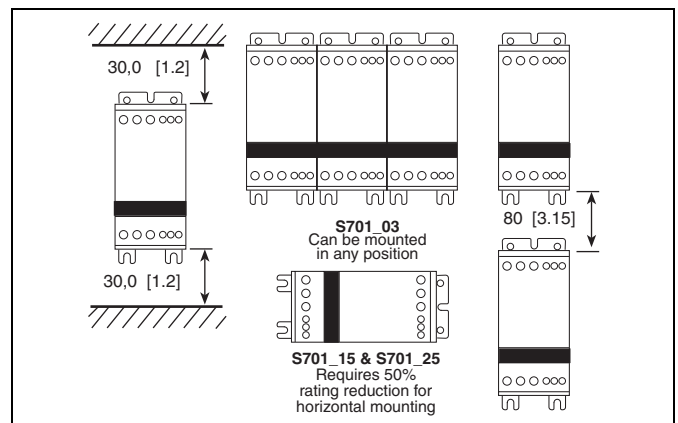

Figure 4. Approx. Dimensions in mm [inches] — Mounting

Specifications

Table 1. Thermal and Mounting Specifications

Specification	S701_03	S701_15, S701_25
Power dissipation (max.) continuous operation	4 Watts	2 Watts per Amp
Power dissipation (max.) intermittent operation	4 Watts x duty cycle	2 Watts per Amp x duty cycle
Cooling method	Natural convection	Natural convection
Operating temperature range, (see Table 6)	-5° to 40°C [23° to 104°F]	-5° to 40°C* [23° to 104°F]
Storage temperature	-20° to 80°C [-4° to 176°F]	-20° to 80°C [-4° to 176°F]
Mounting	Arbitrary	Vertical ±30° Horizontal derate 50%

* UL Tested.

Table 2. Insulation Specifications

Description	Specification
Rated insulation voltage	Ui 660 Volt
Rated impulse withstand voltage	Uimp 4 kVolt
Installation category	III

Environment Specifications

EMC

Protection Degree: IP20

Pollution Degree: 3

Table 3. Output Specifications

Specification	S701_03	S701_15	S701_25
Operational Current (max.)	3.5A AC-53a, AC-3	15A AC-53a, AC-3	25A AC-53a, AC-3
Leakage Current	5 mA AC max.	4 mA AC max.	5 mA AC max.
Operational Current (min.)	50 mA	50 mA	50 mA
Max. Motor Size 208 – 230V AC	0.75 hp (0.1 – 0.55 kW)	5-1/2 hp (0.1 – 4.0 kW)	10 hp (0.1 – 7.5 kW)
Max. Motor Size 380 – 415V AC	1.5 hp (0.1 – 1.1 kW)	10 hp (0.1 – 7.5 kW)	15 hp (0.1 – 11.0 kW)
Max. Motor Size 400 – 480V AC	2 hp (0.1 – 1.5 kW)	10 hp (0.1 – 7.5 kW)	15 hp (0.1 – 11.0 kW)
Max. Motor Size 400 – 600V AC	2 hp (0.1 – 1.5 kW)	10 hp (0.1 – 7.5 kW)	25 hp (0.1 – 18.0 kW)

Table 4. Control Specifications

Control Voltage	S701_03	S701_15	S701_25
C	24 – 240	24 – 240	24 – 240
D	24 – 300	—	—
E	24 – 300	24 – 480	24 – 300
G	24 – 300	24 – 480	24 – 300
Pickup Voltage (max.)	20.4V AC/DC		
Dropout Voltage (min.)	5V AC/DC		
Control Current without operating	1 mA		
Response Time (max.)	70 ms		
Control Current / Power (max.)	15 mA / 2 VA		

Product Selection

Table 5. Product Description and Item Selection

Line Voltage (V AC)	Item No. (3.5 Amp)	Item No. (15 Amp)	Item No. (25 Amp)
208 – 240	S701C03N3S	S701C15N3S	S701C25N3S
400 – 415	S701D03N3S	S701E15N3S	S701E25N3S
440 – 480	S701E03N3S	S701E15N3S	S701E25N3S
550 – 600	S701G03N3S	S701G15N3S	S701G25N3S
Ramp Up Time	Adjustable from 0.5 - 10 seconds		
Ramp Down Time	Adjustable from 0.5 - 10 seconds		
Initial Torque with Optional Kick Start	Adjustable from 0 – 85% of nominal torque		

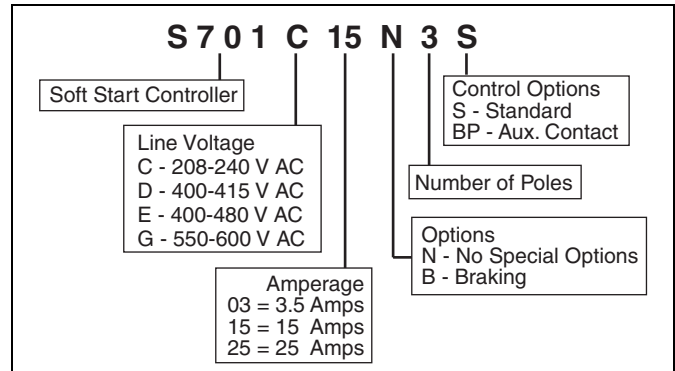

Maintenance

Cooling fins must be kept clean and free from dust. The airflow must not be blocked.

Wiring Diagram

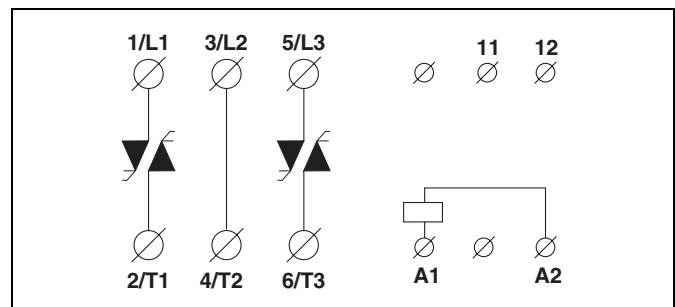

Figure 5. Wiring Diagram

Terminals 11 and 12 have no connection with the internal circuit. They are to be used in conjunction with a thermal overload protection or for other wiring purposes.

NOTE: Use thermal overload protection as required by the National Electric Code (NEC).

Current Derating

Operation in ambient temperatures exceeding 40°C [104°F] is possible if the power dissipation is limited either by reducing the steady-state current or by reducing the duty cycle of the soft starter as shown in **Table 6**.

Table 6. Current Derating

Ambient Temperature	S701_15N3S	S701_25N3S
40° to 50°C [104° to 122°F]	12.5 Amps Continuous or 15 Amps Max. on-time 15 min. Max. duty cycle 0.8	20 Amps Continuous or 25 Amps Max. on-time 15 min. Max. duty cycle 0.8
50° to 60°C [122° to 140°F]	10 Amps Continuous or 15 Amps Max. on-time 15 min. Max. duty cycle 0.65	17 Amps Continuous or 25 Amps Max. on-time 15 min. Max. duty cycle 0.65

Overload Trip Class

10A	15A	25A
10	15A	25A
20	12A	20A
30	10A	15A

Current Derating for S701_03N3S

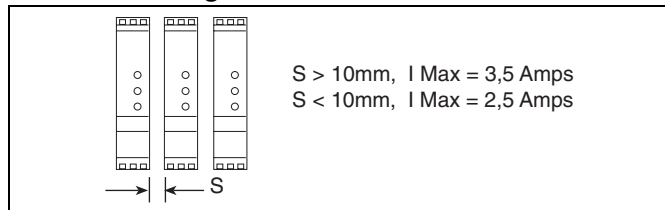

Functional Diagram

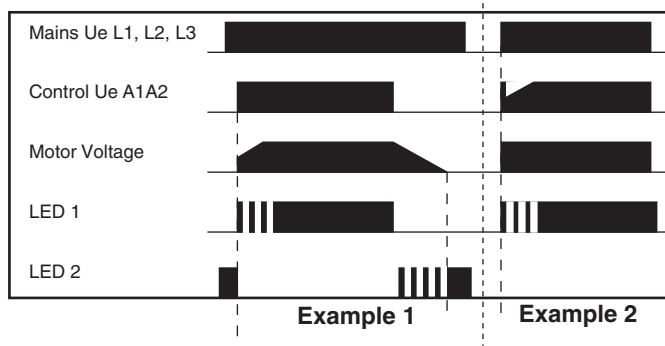

Example 1

Start with initial torque controlled from the input.

Example 2

Soft start with kick start, initial torque.

Soft stop controlled from the mains input.

Utilization Categories (IEC 947-4-2)

Table 7. Utilization Categories

Item	Specification
AC-52a	Control of slip-ring motor stators
AC-53a	Control of squirrel cage motor
AC-58a	Control of hermetic refrigerant compressors with automatic resetting of overload releases

Wiring Directions



When using electrical or pneumatic tools for screw terminals, observe maximum torque limits.

75°C	L1 T1 / L2 T2 / L3 T3	A1 A2 / 11 12
	0.75 – 4 mm ² [18 – 12 AWG]	0.5 – 1.5 mm ² [20 – 16 AWG]
	1.0 mm ² [18 AWG]	0.5 – 0.75 mm ² [20 – 18 AWG]
	0.75 – 6 mm ² [18 – 10 AWG]	0.5 – 1.5 mm ² [20 – 16 AWG]
	0.75 – 2.5 mm ² [18 – 14 AWG]	0.5 – 1.5 mm ² [20 – 16 AWG]
	0.75 – 6 mm ² [18 – 10 AWG]	0.5 – 1.5 mm ² [20 – 16 AWG]
	0.75 – 1.5 mm ² [18 – 16 AWG]	0.5 – 1.5 mm ² [20 – 16 AWG]
	Posidrive 1 0.5 Nm max. [4.4 lb-in max.]	N/A
	4 mm 0.5 Nm max. [4.4 lb-in max.]	3 mm 0.4 Nm max. [3.5 lb-in max.]

* UL Tested.

Short Circuit Protection

Short circuit protection is divided into two levels — Type 1 and Type 2.

Type 1 — protects the installation

Type 2 — protects the installation and the semiconductors inside the motor controller

Short Circuit Protection by Circuit Breaker

A 3-phase motor with a correctly installed and adjusted overload relay will not short-circuit totally to earth or between the 3 phases. Part of the winding will normally limit the short circuit current to a value that will cause instantaneous magnetic tripping of the circuit breaker without damage to the soft starter. The magnetic trip response current is approximately 11 times the maximum adjustable current.

Short Circuit Protection by Fuses

Type 1

S701_03N3S — protection max. 25A_{gI/gL/gG}

S701_15N3S — protection max. 50A_{gI/gL/gG}

S701_25N3S — protection max. 80A_{gI/gL/gG} 63A T

Type 2

S701_03N3S — protection max. I²t of the fuse 72A²S

S701_15N3S — protection max. I²t of the fuse 1800A²S

S701_25N3S — protection max. I²t of the fuse 6300A²S

NOTE: S701_25N3S — When protected by a non-time delay K5 or H class fuse rated 266% of motor FLA, this device is rated for use on a circuit capable of delivering not more than 5000 rms symmetrical amperes, 600V maximum.

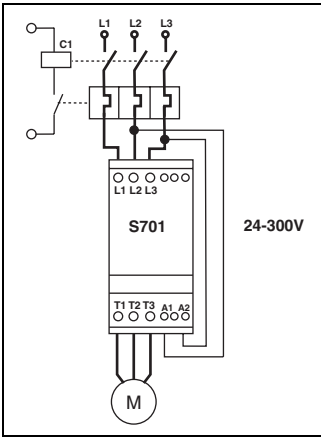

Figure 6. Line Controlled Soft Start *

Using Line Voltage to Control S701

When the contactor C1 is switched to the ON state, the motor controller will soft start the motor according to the settings of the ramp-up time and initial torque adjustments.

When the contactor C1 is switched to the OFF state, the motor will be switched off instantaneously.

In this application, the contactor will have no load during making operation.

The contactor will carry and break the nominal motor current. Maximum voltage in this application is 300V AC.

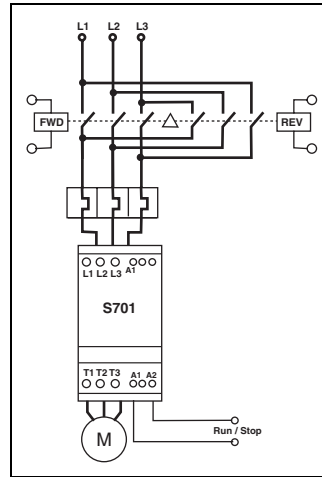

Figure 9. Reversing of Motors *

Reversing of Motors Up to 15 hp/11 kW

A soft-reversing of motors can easily be achieved when the motor load exceeds 5 hp/4 kW by connecting a mechanical reversing contactor to the soft start controller.

The reversing contactor will determine the direction of rotation forward or reverse and the soft start type S701 will perform soft-starting and soft-stopping of the motor.

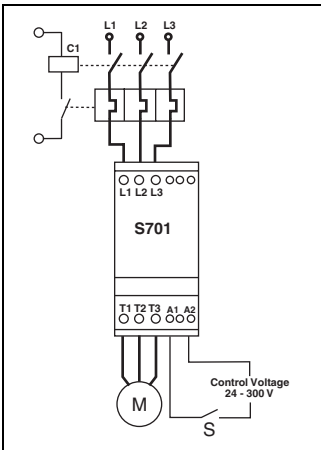

Figure 7. Input Controlled Soft Start *

Separate Input Signal to S701

When the control input is switched to the ON state (S closed), the motor controller will soft start the motor according to the settings of the ramp-up time and initial torque adjustments.

When the control input is switched to the OFF state (S open), the motor will be switched off instantaneously only if the ramp-down time is adjusted to 0.

With any other setting, the motor will be soft stopped according to the settings of the ramp-down time adjustment.

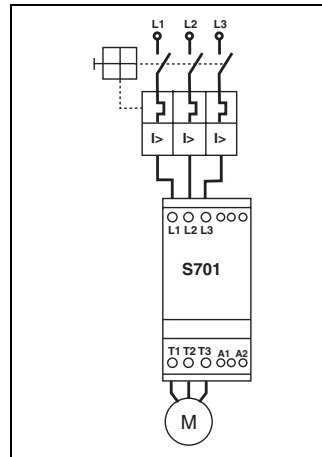

Figure 10. Overload Protection with Manual Motor Starter *

Overload Protection with Manual Starter

Overload protection of the motor is easily achieved by installing a manual motor starter on the supply side of the motor.

The manual motor starter provides means for padlocking and the necessary clearance for use as a circuit isolator according to EN60204-1.

Adjust the current on the manual motor starter according to the rated nominal current of the motor.

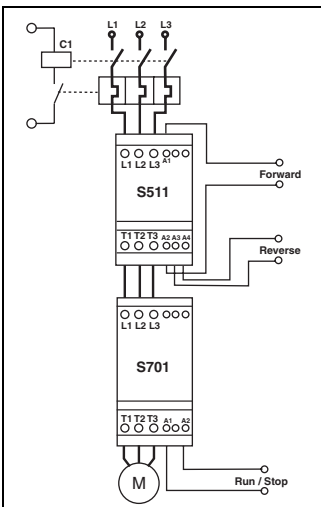

Figure 8. Soft Reversing of Motors*

Soft Reversing of Motors up to 5 hp/4 kW

A soft reversing of a motor can easily be achieved by connecting a reversing relay to the soft starter.

The reversing contactor type S511 will determine the direction of rotation forward or reverse and the soft start type S701 will perform soft-starting and soft-stopping of the motor.

If soft stop is not required, the application can be simplified by connecting the control circuit of the soft start controller to the main terminals as shown in **Figure 6**. A delay of approximately 0.5 seconds between forward and reverse control signal must be

allowed to avoid influence from the voltage generated by the motor during turnoff.

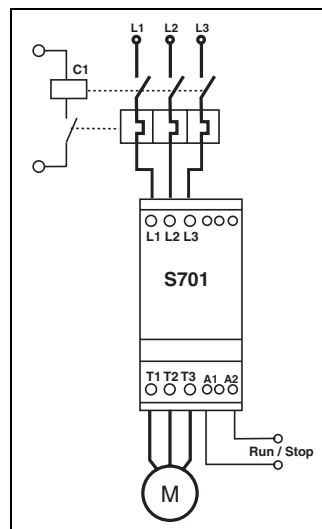

Figure 11. Overload Protection with Mechanical Starter *

Overload Protection with Mechanical Starter

Overload protection of the motor is easily achieved by installing a mechanical starter on the supply side of the soft start controller.

The overload provides the necessary motor protection for an overload condition.

A short circuit protective device is required to meet UL requirements.

* Use specified backup fuse or circuit breaker.

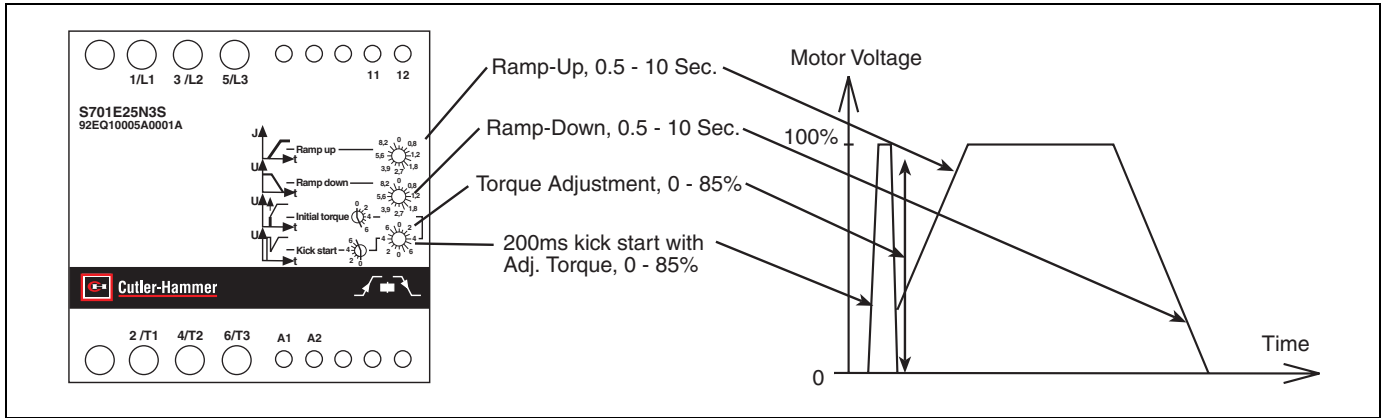

Figure 12. Adjust Time and Torque

How to Adjust Time and Torque, Figure 12

Control of the motor torque is achieved by acting on the motor voltage. The motor speed depends on the torque produced by the motor and the load on the motor shaft. A motor with little or no load will reach full speed before the voltage has reached its maximum value.

NOTE: The soft start controller will read time and torque settings in the OFF state. Repeated starts may trip the motor protection relay. DO NOT set the rotary switches in between positions. This corrupts the time and torque adjustment. Use screwdriver 2 mm x 0.5 mm.

Rating Index

Table 8. Rating Index

S701_15N3S	S701_25N3S
15A: AC-52a: 4-13 : 100 – 3000	25A: AC-52a: 4-13 : 100 – 3000
15A: AC-53a: 8-3 : 100 – 3000	25A: AC-53a: 8-3 : 100 – 3000
15A: AC-58a: 6-6 : 100 – 3000	25A: AC-58a: 6-6 : 100 – 3000

Ramp-Up Time and Initial Torque

Table 9. Ramp-Up Time and Initial Torque (Standard Load)

Position	Setting/Adjustment
	Set the Ramp-Up switch to maximum.
	Set the Ramp-Down switch to minimum.
	Set the Initial Torque switch to minimum.
	Apply control signal for a few seconds. If the load does not rotate immediately, increment the Initial Torque and try again. Repeat until the load starts to rotate immediately on startup.
	Adjust Ramp-Up time to the estimated start time (the scale is in seconds) and start the motor.
	Decrease the Ramp-Up time until mechanical surge is observed during start.
	Increase the time one step to eliminate the surge.

Kick Start/Break Loose

If it is not possible to reach a time sufficient for the application, it may be necessary to kick start the load.

Table 10. Kick Start/Break Loose (High Inertia Loads)

Position	Setting/Adjustment
	Set the Ramp-Up switch to maximum.
	Set the Ramp-Down switch to minimum.
	Set the Initial Torque switch to minimum kick start torque.
	Apply control signal for a few seconds. If the load stops right after the 200ms “kick”, increment the Initial Torque and try again. Repeat until the load continues to rotate after the “kick”.
	Adjust Ramp-Up time to the desired start time (the scale is in seconds) and start the motor.

Ramp-Down Time

Follow Table 9 to set **Ramp-Up** and **Initial Torque**.

Table 11. Ramp-Down Time, e.g. Pump Loads

Position	Setting/Adjustment
	Set the Ramp-Down switch to maximum.
	Switch off the control voltage and observe any mechanical surges on the load. If there are none, decrement Ramp-Down switch and try again. Repeat until mechanical surge on the load is observed.
	Increase the time one step to eliminate the surge.

