

# ***FRENIC-MEGA***

---



## General Specifications

# 1. Standard Specifications

## 1) Three-phase 230 V series

### HD mode - designed for heavy duty load applications

Item		Specifications																		
Type (FRN□□□G1S-2U)		F50	001	002	003	005	007	010	015	020	025	030	040	050	060	075	100	125	150	
Nominal applied motor <sup>*1</sup> for three phase input [HP]		1/2	1	2	3	5	7.5	7.5	10	15	20	25	30	40	50	60	75	100	125	
Nominal applied motor <sup>*1</sup> for single phase input [HP]		1/4	1/2	1	1.5	3	3	3	5	7.5	10	10	15	20	25	30	30	40	40	
Output ratings	Three phase input	Rated capacity <sup>*2</sup> [kVA]	1.2	2.0	3.2	4.4	7.2	11	11	15	20	25	30	36	47	58	72	86	113	138
		Rated current [A]	3	5	8	11	18	27	27	37	49	63	76	90	119	146	180	215	283	346
	Single phase input	Rated capacity <sup>*2</sup> [kVA]	0.8	1.3	1.9	2.6	4.4	6.8	6.8	9.2	10	13	15	18	24	30	37	38	44	52
		Rated current [A]	1.9	3.1	4.7	6.3	11	17	17	23	26	33	38	45	61	75	93	95	109	131
Rated voltage <sup>*3</sup> [V]		Three-phase, 200 to 240 V (with AVR function)												Three-phase 200 to 230 V(with AVR functi						
Overload capability		150% -1 min, 200% -3.0 s																		
Input ratings	Three phase input	Voltage, frequency	Three-phase, 200 to 240 V, 50/60 Hz												Three-phase, 200 to 220 V, 50 Hz Three-phase, 200 to 230 V, 60 Hz					
		Voltage, frequency variations	Voltage: +10 to -15% (Interphase voltage unbalance: 2% or less) <sup>*4</sup> , Frequency: +5 to -5%																	
		Input current with DCR	1.5	3	5.5	7.7	13	18.5	18.5	25.1	37.6	50.2	62.7	75.3	100	120	145	178	246	291
		Input current without DCR	2.8	4.7	8.5	11.9	20	28.4	28.4	38.6	54.8	72.4	87.7	101	136	167	203	-		
	Single phase input	Required capacity with DCR <sup>*5</sup> [kVA]	0.6	1.2	2.2	3.1	5.2	7.4	7.4	10	15	20	25	30	40	48	58	71	98	116
		Voltage, frequency	Single-phase, 200 to 240 V, 50/60Hz												Single-phase, 200 to 220 V, 50 Hz Single-phase, 200 to 230 V, 60 Hz					
		Voltage, frequency variations	Voltage: +10 to -10% , Frequency: +5 to -5%																	
		Input current with DCR	2.0	3.5	6.6	9.5	17.2	25.1	25.1	33.1	41.8	56.1	67.7	79	114	143	172	181	218	252
Input current without DCR	3.1	5.3	9.5	13.2	22.2	31.5	31.5	42.7	60.7	80.1	97	112	151	185	225	228	-			
Required capacity with DCR <sup>*5</sup> [kVA]	0.5	0.9	1.6	2.2	4.0	5.8	5.8	7.7	9.7	13	16	18	26	33	40	42	50	58		
Braking	Torque <sup>*6</sup> [%]	150%			100%						20%			10 to 15%						
	Braking transistor	Built-in																		
	Built-in braking resistor	Built-in																		
	Braking time [s]	5 s																		
%ED	5	3	5	3	2	3	3	2	-											
DC reactor (DCR)	Option															Standard (*7)				
KEY PAD	Multi-function keypad as standard, Remote keypad with USB (Option)																			
Applicable safety standards	UL508C, C22.2 No.14, EN61800-5-1:2007																			
Enclosure (IEC60529)	IP20, UL open type , NEMA1(Option)												IP00, UL open type , NEMA1(Option)							
Cooling method	Natural cooling			Fan cooling																
Weight/Mass [lbs(kg)]	3.8	4.4	6.2	6.6	6.6	14.3	14.3	14.3	12.8	20.9	20.9	22	55.1	70.6	92.6	94.8	137	231		
	(1.7)	(2.0)	(2.8)	(3.0)	(3.0)	(6.5)	(6.5)	(6.5)	(5.8)	(9.5)	(9.5)	(10)	(25)	(32)	(42)	(43)	(62)	(105)		

(\*1) Fuji 4-pole standard motor

(\*2) Rated capacity is calculated by assuming the output rated voltage as 230 V for 230 V series and 460 V for 460 V series.

(\*3) Output voltage cannot exceed the power supply voltage. At single-phase input use, the output voltage may be lower than three-phase input.

(\*4) Voltage unbalance [%] = (Max. voltage [V] - Min. voltage [V])/Three-phase average voltage [V]×67(See IEC61800-3.)

If this value is 2 to 3%, use an optional AC reactor (ACR).

(\*5) Required when a DC reactor (DCR) is used.

(\*6) Without external braking resistor condition. Average braking torque for the motor running alone. (It varies with the efficiency of the motor.)

(\*7) For Inverters of 100HP or above , the DC reactor is provided as separate standard component. Be sure to connect it to those inverters.

### LD mode - designed for light duty load applications

Item		Specifications																			
Type (FRN□□□G1S-2U)		F50	001	002	003	005	007	010	015	020	025	030	040	050	060	075	100	125	150		
Nominal applied motor <sup>*1</sup> for three phase input [HP]		1/2	1	2	3	5	7.5	10	15	20	25	30	40	50	60	75	100	125	150		
Nominal applied motor <sup>*1</sup> for single phase input [HP]		1/4	1/2	1	1.5	3	3	5	7.5	10	10	15	20	25	30	30	30	40	50		
Output ratings	Three phase input	Rated capacity <sup>*2</sup> [kVA]	1.2	2.0	3.2	4.4	7.2	11	13	18	24	30	35	46	58	72	86	113	138	165	
		Rated current <sup>*4</sup> [A]	3	5	8	11	18	27	31.8 (29)	46.2 (42)	59.4 (55)	74.8 (68)	88 (80)	115 (107)	146	180	215	283	346	415	
	Single phase input	Rated capacity <sup>*2</sup> [kVA]	0.8	1.3	1.9	2.6	4.4	6.8	9.2	12	13	16	18	23	30	37	38	41	52	59	
		Rated current [A]	1.9	3.1	4.7	6.3	11	17	23	30	32	39	44	58	74	93	95	102	131	149	
	Rated voltage <sup>*3</sup> [V]		Three-phase, 200 to 240 V (with AVR function)											Three-phase 200 to 230 V (with AVR function)							
	Overload capability		150% -1 min, 200% -3.0 s							120% -1 min											
Input ratings	Three phase input	Voltage, frequency	Three-phase, 200 to 240 V, 50/60 Hz											Three-phase, 200 to 220 V, 50 Hz					Three-phase, 200 to 230 V, 60 Hz		
		Voltage, frequency variations	Voltage: +10 to -15% (Interphase voltage unbalance: 2% or less) <sup>*5</sup> , Frequency: +5 to -5%																		
		Input current with DCR	1.5	3	5.5	7.7	13	18.5	25.1	37.6	50.2	62.7	75.3	100	120	145	178	246	291	358	
		Input current without DCR	2.8	4.7	8.5	11.9	20	28.4	38.6	54.8	72.4	87.7	101	136	167	203	244	-			
		Required capacity with DCR <sup>*6</sup> [kVA]	0.6	1.2	2.2	3.1	5.2	7.4	10.0	15.0	20.0	25.0	30.0	40.0	48.0	58.0	71.0	98.0	116	143	
	Single phase input	Voltage, frequency	Single-phase, 200 to 240 V, 50/60 Hz											Single-phase, 200 to 220 V, 50 Hz						Single-phase, 200 to 230 V, 60 Hz	
		Voltage, frequency variations	Voltage: +10 to -10% , Frequency: +5 to -5%																		
		Input current with DCR	2.0	3.5	6.6	9.5	17.2	25.1	34.0	47.0	55.1	67.9	78.1	107	140	173	179	202	258	293	
		Input current without DCR	3.1	5.3	9.5	13.2	22.2	31.5	42.7	60.7	80.1	97	112	151	185	225	233	-			
		Required capacity with DCR <sup>*6</sup> [kVA]	0.5	0.9	1.6	2.2	4.0	5.8	7.9	11	13	16	18	25	32	40	41	47	59	67	
Braking	Torque <sup>*7</sup> [%]		150%			100%			70%			15%			7 to 12%						
	Braking transistor		Built-in																		
	Built-in braking resistor		Built-in											-							
	Braking time [s]		5 s					3.7 s	3.7 s	3.4 s	-										
	%ED		5	3	5	3	2	2.2	2.2	1.4	-										
DC reactor (DCR)		Option														As standard *8					
KEY PAD		Multi-function keypad as standard, Remote keypad with USB (Option)																			
Applicable safety standards		UL508C, C22.2 No.14, EN61800-5-1:2007																			
Enclosure (IEC60529)		IP20, UL open type , NEMA1(Option)											IP00, UL open type , NEMA1(Option)								
Cooling method		Natural cooling					Fan cooling														
Weight/Mass [lbs(kg)]		3.8 (1.7)	4.4 (2.0)	6.2 (2.8)	6.6 (3.0)	6.6 (3.0)	14.3 (6.5)	14.3 (6.5)	14.3 (6.5)	12.8 (5.8)	20.9 (9.5)	20.9 (9.5)	22 (10)	55.1 (25)	70.6 (32)	92.6 (42)	94.8 (43)	137 (62)	231 (105)		

(\*1) Fuji 4-pole standard motor

(\*2) Rated capacity is calculated by assuming the output rated voltage as 230 V for 230 V series and 460 V for 460 V series.

(\*3) Output voltage cannot exceed the power supply voltage. At single-phase input use, the output voltage may be lower than three-phase input.

(\*4) To use the inverter with the carrier frequency of 3 kHz or more at the surrounding temperature of 40°C(104°F) or higher, manage the load so that the current comes to be within the rated ones enclosed in parentheses ( ) in continuous running.

(\*5) Voltage unbalance [%] = (Max. voltage [V] - Min. voltage [V])/Three-phase average voltage [V]×67(See IEC61800-3.)

If this value is 2 to 3%, use an optional AC reactor (ACR).

(\*6) Required when a DC reactor (DCR) is used.

(\*7) Without external braking resistor condition. Average braking torque for the motor running alone. (It varies with the efficiency of the motor.)

(\*8) For Inverters of 100HP or above , the DC reactor is provided as separate standard component. Be sure to connect it to those inverters.

**2) Three-phase 460 V series**  
**HD mode - designed for heavy duty load applications**

Item		Specifications																			
Type (FRN□□□G1S-4U)		F50	001	002	003	005	007	010	015	020	025	030	040	050	060	075	100	-	-		
Nominal applied motor <sup>*1</sup> for three phase input [HP]		1/2	1	2	3	5	7.5	7.5	10	15	20	25	30	40	50	60	75	-	-		
Nominal applied motor <sup>*1</sup> for single phase input [HP]		1/4	1/2	1	1.5	3	3	3	5	7.5	10	10	15	20	25	30	30	-	-		
Output ratings	Three phase input	Rated capacity <sup>*2</sup> [kVA]	1.2	2.0	3.2	4.4	7.2	11	11	15	20	25	31	36	48	60	73	89	-	-	
		Rated current [A]	1.5	2.5	4	5.5	9	13.5	13.5	18.5	24.5	32	39	45	60	75	91	112	-	-	
	Single phase input	Rated capacity <sup>*2</sup> [kVA]	0.8	1.2	2.0	2.4	4.5	6.4	6.4	9.6	10	14	16	18	24	30	36	44	-	-	
		Rated current [A]	0.9	1.5	2.4	3.0	5.6	8.0	8.0	12	13	17	20	23	30	38	45	55	-	-	
	Rated voltage <sup>*3</sup> [V]		Three-phase, 380 to 480 V (with AVR function)																		
	Overload capability		150% -1 min, 200% -3.0 s																		
Input ratings	Three phase input	Voltage, frequency	Three-phase, 380 to 480 V, 50/60 Hz																		
		Voltage, frequency variations	Voltage: +10 to -15% (Interphase voltage unbalance: 2% or less) <sup>*4</sup> , Frequency: +5 to -5%																		
		Input current with DCR	0.7	1.5	2.6	4	6.6	9.2	9.2	12.4	18.8	25	31	36	50	60	72	89	-	-	
		Input current without DCR	1.4	2.6	5.1	7.1	11.3	15	15	20.1	28.6	38	45.4	52.6	67.7	82	99.1	-	-	-	
		Required capacity with DCR <sup>*5</sup> [kVA]	0.6	1.2	2.1	3.2	5.3	7.4	7.4	9.9	15.0	20.0	25.0	29.0	40.0	48.0	58.0	71.0	-	-	
	Single phase input	Voltage, frequency	Single-phase, 380 to 480 V, 50/60 Hz																		
		Voltage, frequency variations	Voltage: +10 to -10% , Frequency: +5 to -5%																		
		Input current with DCR	1.0	1.8	3.5	4.7	8.5	11.7	11.7	16.8	21.5	29	34.5	41.6	57.1	69.7	84.5	106	-	-	
		Input current without DCR	1.7	3.1	5.9	8.2	13.0	17.3	17.3	23.2	33	43.8	52.3	60.6	77.9	94.3	114	140	-	-	
		Required capacity with DCR <sup>*5</sup> [kVA]	0.5	0.9	1.7	2.2	4.0	5.4	5.4	7.8	9.9	13	16	19	26	32	39	49	-	-	
Braking	Torque <sup>*6</sup> [%]	150%			100%						20%			10 to 15%						-	-
	Braking transistor	Built-in																			
	Built-in braking resistor	Built-in																			
	Braking time [s]	5 s																			
	%ED	5	3	5	3	2	3	3	2											-	-
DC reactor (DCR)	Option																As standard *7				
KEY PAD	Multi-function keypad as standard, Remote keypad with USB (Option)																				
Applicable safety standards	UL508C, C22.2 No.14, EN61800-5-1:2007																				
Enclosure (IEC60529)	IP20, UL open type , NEMA1(Option)												IP00 UL open type , NEMA1(Option)								
Cooling method	Natural cooling						Fan cooling														
Weight/Mass [lbs(kg)]	3.8 (1.7)	4.4 (2.0)	5.7 (2.6)	6.0 (2.7)	6.6 (3.0)	14.3 (6.5)	14.3 (6.5)	14.3 (6.5)	12.8 (5.8)	20.9 (9.5)	20.9 (9.5)	22 (10)	55.1 (25)	57.3 (26)	68.3 (31)	72.8 (33)	-	-			

(\*1) Fuji 4-pole standard motor

(\*2) Rated capacity is calculated by assuming the output rated voltage as 230 V for 230 V series and 460 V for 460 V series.

(\*3) Output voltage cannot exceed the power supply voltage. At single-phase input use, the output voltage may be lower than three-phase input.

(\*4) Voltage unbalance [%] = (Max. voltage [V] - Min. voltage [V])/Three-phase average voltage [V]\*67(See IEC61800-3.)

If this value is 2 to 3%, use an optional AC reactor (ACR).

(\*5) Required when a DC reactor (DCR) is used.

(\*6) Without external braking resistor condition. Average braking torque for the motor running alone. (It varies with the efficiency of the motor.)

(\*7) For Invertrers of 100HP or above , the DC reactor is provided as separate standard component. Be sure to connect it to those inverters.

### HD mode - designed for heavy duty load applications

Item		Specifications															
Type (FRN□□□G1S-4U)		125	150	200	250	300	350	450	500	600	700	800	900	1000	-	-	
Nominal applied motor <sup>1</sup> for three phase input [HP]		100	125	150	200	250	300	350	400	450	500	600	800	900	-	-	
Nominal applied motor <sup>1</sup> for single phase input [HP]		40	50	60	60	75	100	100	125	150	150	200	250	300	-	-	
Output ratings	Three phase input	Rated capacity <sup>2</sup> [kVA]	120	140	167	202	242	300	330	414	466	518	590	765	932	-	-
		Rated current [A]	150	176	210	253	304	377	415	520	585	650	740	960	1170	-	-
	Single phase input	Rated capacity <sup>2</sup> [kVA]	48	57	68	82	97	118	133	162	184	206	236	305	373	-	-
		Rated current [A]	61	72	86	103	122	149	167	204	231	259	297	384	469	-	-
	Rated voltage <sup>3</sup> [V]		Three-phase, 380 to 480 V (with AVR function)														
	Overload capability		150%-1 min, 200% -3.0 s														
Input ratings	Three phase input	Voltage, frequency	Three-phase, 380 to 440 V, 50 Hz Three-phase, 380 to 480 V, 60 Hz														
		Voltage, frequency variations	Voltage: +10 to -15% (Interphase voltage unbalance: 2% or less) <sup>4</sup> , Frequency: +5 to -5%														
		Input current with DCR	120	143	176	207	250	311	340	436	487	547	614	767	970	-	-
	Required capacity with DCR <sup>5</sup> [kVA]	96	114	140	165	199	248	271	347	388	436	489	611	773	-	-	
	Single phase input	Voltage, frequency	Single-phase, 380 to 440 V, 50 Hz Single-phase, 380 to 480 V, 60 Hz														
		Voltage, frequency variations	Voltage: +10 to -10% , Frequency: +5 to -5%														
Input current with DCR		113	137	164	192	234	286	319	395	446	512	575	707	892	-	-	
Required capacity with DCR <sup>5</sup> [kVA]	53	63	76	89	108	132	147	182	206	236	265	325	410	-	-		
Braking	Torque <sup>6</sup> [%]	10 to 15 %															
	Braking transistor	-															
DC reactor (DCR)		As standard *7															
KEY PAD		Multi-function keypad as standard, Remote keypad with USB (Option)															
Applicable safety standards		UL508C, C22.2 No.14, EN61800-5-1:2007															
Enclosure (IEC60529)		IP00, UL open type , NEMA1(Option)															
Cooling method		Fan cooling															
Weight/Mass [lbs(kg)]		93 (42)	137 (62)	141 (64)	207 (94)	216 (98)	284 (129)	309 (140)	540 (245)	540 (245)	805 (365)	805 (365)	1170 (530)	1170 (530)	-	-	

(\*1) Fuji 4-pole standard motor

(\*2) Rated capacity is calculated by assuming the output rated voltage as 230 V for 230 V series and 460 V for 460 V series.

(\*3) Output voltage cannot exceed the power supply voltage. At single-phase input use, the output voltage may be lower than three-phase input.

(\*4) Voltage unbalance [%] = (Max. voltage [V] - Min. voltage [V])/Three-phase average voltage [V]×67(See IEC61800-3.)

If this value is 2 to 3%, use an optional AC reactor (ACR).

(\*5) Required when a DC reactor (DCR) is used.

(\*6) Without external braking resistor condition. Average braking torque for the motor running alone. (It varies with the efficiency of the motor.)

(\*7) For Inverters of 100HP or above , the DC reactor is provided as separate standard component. Be sure to connect it to those inverters.

### MD mode - designed for middle duty load applications

Item		Specifications														
Type (FRN□□□G1S-4U)		150	200	250	300	350	450	500	600	700	800	-	-	-	-	
Nominal applied motor <sup>1</sup> for three phase input [HP]		150	200	250	300	350	350	450	500	600	700	-	-	-	-	
Nominal applied motor <sup>1</sup> for single phase input [HP]		-	-	-	-	-	-	-	-	-	-	-	-	-	-	
Output ratings	Three phase input	Rated capacity <sup>2</sup> [kVA]	167	202	242	300	331	373	466	518	590	669	-	-	-	-
		Rated current [A]	210	253	304	377	415	468	585	650	740	840	-	-	-	-
	Single phase input	Rated capacity <sup>2</sup> [kVA]	-	-	-	-	-	-	-	-	-	-	-	-	-	-
		Rated current [A]	-	-	-	-	-	-	-	-	-	-	-	-	-	-
	Rated voltage <sup>3</sup> [V]		Three-phase, 380 to 480 V (with AVR function)													
	Overload capability		150% -1 min													
Input ratings	Three phase input	Voltage, frequency	Three-phase, 380 to 440 V, 50 Hz Three-phase, 380 to 480 V, 60 Hz													
		Voltage, frequency variations	Voltage: +10 to -15% (Interphase voltage unbalance: 2% or less) <sup>4</sup> , Frequency: +5 to -5%													
		Input current with DCR	175	207	249	311	340	386	486	547	613	686	-	-	-	-
		Required capacity with DCR <sup>5</sup> [kVA]	140	165	199	248	271	308	388	436	489	547	-	-	-	-
	Single phase input	Voltage, frequency	Single-phase, 380 to 440 V, 50 Hz Single-phase, 380 to 480 V, 60 Hz													
		Voltage, frequency variations	Voltage: +10 to -10% , Frequency: +5 to -5%													
		Input current with DCR	-	-	-	-	-	-	-	-	-	-	-	-	-	-
		Required capacity with DCR <sup>5</sup> [kVA]	-	-	-	-	-	-	-	-	-	-	-	-	-	-
Braking	Torque <sup>6</sup> [%]	7 to 12%														
	Braking transistor	-														
DC reactor (DCR)		As standard *7														
KEY PAD		Multi-function keypad as standard, Remote keypad with USB (Option)														
Applicable safety standards		UL508C, C22.2 No.14, EN61800-5-1:2007														
Enclosure (IEC60529)		IP00, UL open type , NEMA1(Optional)														
Cooling method		Fan cooling														
Weight/Mass [lbs(kg)]		137 (62)	141 (64)	207 (94)	216 (98)	284 (129)	309 (140)	540 (245)	540 (245)	805 (365)	805 (365)	-	-	-	-	

(\*1) Fuji 4-pole standard motor

(\*2) Rated capacity is calculated by assuming the output rated voltage as 230 V for 230 V series and 460 V for 460 V series.

(\*3) Output voltage cannot exceed the power supply voltage.

(\*4) Voltage unbalance [%] = (Max. voltage [V] - Min. voltage [V])/Three-phase average voltage [V]×67(See IEC61800-3.)

If this value is 2 to 3%, use an optional AC reactor (ACR).

(\*5) Required when a DC reactor (DCR) is used.

(\*6) Without external braking resistor condition. Average braking torque obtained by use of a motor. (Varies with the efficiency of the motor.)

(\*7) For Inverters of 100HP or above , the DC reactor is provided as separate standard component. Be sure to connect it to those inverters.

**LD mode - designed for light duty load applications**

Item		Specifications																		
Type (FRN□□□G1S-4U)		F50	001	002	003	005	007	010	015	020	025	030	040	050	060	075	100	-	-	
Nominal applied motor <sup>*1</sup> for three phase input [HP]		1/2	1	2	3	5	7.5	10	15	20	25	30	40	50	60	75	100	-	-	
Nominal applied motor <sup>*1</sup> for single phase input [HP]		1/4	1/2	1	1.5	3	3	5	7.5	10	10	15	20	25	30	30	40	-	-	
Output ratings	Three phase input	Rated capacity <sup>*2</sup> [kVA]	1.2	2.0	3.2	4.4	7.2	11	13.1	18.3	24	29	36	48	60	73	89	120	-	-
		Rated current [A]	1.5	2.5	4	5.5	9	13.5	16.5	23	30.5	37	45	60	75	91	112	150	-	-
	Single phase input	Rated capacity <sup>*2</sup> [kVA]	0.8	1.2	2.0	2.4	4.5	6.4	8.8	12	14	16	18	23	30	37	43	47	-	-
		Rated current [A]	0.9	1.5	2.4	3.0	5.6	8.0	11	15	17	20	23	29	37	46	54	59	-	-
	Rated voltage <sup>*3</sup> [V]		Three-phase, 380 to 480 V (with AVR function)																	
	Overload capability		150% -1 min, 200% -3.0 s							120% -1 min										
Input ratings	Three phase input	Voltage, frequency		Three-phase, 380 to 480 V, 50/60 Hz																
		Voltage, frequency variations		Voltage: +10 to -15% (Interphase voltage unbalance: 2% or less) <sup>*4</sup> , Frequency: +5 to -5%																
		Input current with DCR	0.7	1.5	2.6	4	6.6	9.2	12.5	18.8	25.1	31.3	36.3	50.2	60.2	72.7	89.1	120	-	-
		Input current without DCR	1.4	2.6	5.1	7.1	11.3	15	20.1	28.6	38	45.4	52.6	67.7	82	99.1	121	-	-	-
	Required capacity with DCR <sup>*5</sup> [kVA]		0.6	1.2	2.2	3.1	5.2	7.4	10	15	20	25	29	40	48	58	71	96	-	-
	Single phase input	Voltage, frequency		Single-phase, 380 to 480 V, 50/60 Hz																
		Voltage, frequency variations		Voltage: +10 to -10% , Frequency: +5 to -5%																
		Input current with DCR	1.0	1.8	3.5	4.7	8.5	11.7	15.7	24	28.6	34.6	40	53.4	69.1	84.3	99.7	110	-	-
		Input current without DCR	1.7	3.1	5.9	8.2	13.0	17.3	23.2	33	43.8	52.3	60.6	77.9	94.3	114	134	-	-	-
	Required capacity with DCR <sup>*5</sup> [kVA]		0.5	0.9	1.7	2.2	4.0	5.4	7.3	11	13	16	18	25	32	39	46	51	-	-
Braking	Torque <sup>*6</sup> [%]		150%			100%			70%			15%			7 to 12%			-	-	
	Braking transistor		Built-in																	
	Built-in braking resistor		Built-in																	
	Braking time [s]		5 s					3.7s	3.7s	3.4s										
%ED		5	3	5	3	2	2.2	2.2	1.4											
DC reactor (DCR)		Option															As standard *7			
KEY PAD		Multi-function keypad as standard, Remote keypad with USB (Option)																		
Applicable safety standards		UL508C, C22.2 No.14, EN61800-5-1:2007																		
Enclosure (IEC60529)		IP20, UL open type , NEMA1(Option)											IP00 UL open type , NEMA1(Option)							
Cooling method		Natural cooling					Fan cooling													
Weight/Mass [lbs(kg)]		3.8 (1.7)	4.4 (2.0)	5.7 (2.6)	6.0 (2.7)	6.6 (3.0)	14.3 (6.5)	14.3 (6.5)	14.3 (6.5)	12.8 (5.8)	20.9 (9.5)	20.9 (9.5)	22 (10)	55.1 (25)	57.3 (26)	68.3 (31)	72.8 (33)	-	-	

(\*1) Fuji 4-pole standard motor

(\*2) Rated capacity is calculated by assuming the output rated voltage as 230 V for 230 V series and 460 V for 460 V series.

(\*3) Output voltage cannot exceed the power supply voltage. At single-phase input use, the output voltage may be lower than three-phase input.

(\*4) Voltage unbalance [%] = (Max. voltage [V] - Min. voltage [V])/Three-phase average voltage [V]×67(See IEC61800-3.)

If this value is 2 to 3%, use an optional AC reactor (ACR).

(\*5) Required when a DC reactor (DCR) is used.

(\*6) Without external braking resistor condition. Average braking torque obtained by use of a motor. (Varies with the efficiency of the motor.)

(\*7) For Invertracs of 100HP or above , the DC reactor is provided as separate standard component. Be sure to connect it to those inverters.

### LD mode - designed for light duty load applications

Item		Specifications															
Type (FRN□□□G1S-4U)		125	150	200	250	300	350	450	500	600	700	800	900	1000	-	-	
Nominal applied motor <sup>*1</sup> for three phase input [HP]		125	150	200	250	300	350	450	500	600	700	800	900	1000	-	-	
Nominal applied motor <sup>*1</sup> for single phase input [HP]		50	50	60	75	100	100	125	150	200	200	250	300	400	-	-	
Output ratings	Three phase input	Rated capacity <sup>*2</sup> [kVA]	140	167	202	242	300	331	414	518	590	669	765	932	1092	-	-
		Rated current [A]	176	210	253	304	377	415	520	650	740	840	960	1170	1370	-	-
	Single phase input	Rated capacity <sup>*2</sup> [kVA]	55	65	78	96	116	128	160	198	229	259	305	368	461	-	-
		Rated current [A]	70	82	99	121	146	161	202	250	288	326	384	462	579	-	-
	Rated voltage <sup>*3</sup> [V]		Three-phase, 380 to 480 V (with AVR function)														
	Overload capability		120% -1 min														
Input ratings	Three phase input	Voltage, frequency	Three-phase, 380 to 440 V, 50 Hz Three-phase, 380 to 480 V, 60 Hz														
		Voltage, frequency variations	Voltage: +10 to -15% (Interphase voltage unbalance: 2% or less) <sup>*4</sup> , Frequency: +5 to -5%														
		Input current with DCR	143	175	207	249	311	340	435	547	613	686	766	970	1093	-	-
		Required capacity with DCR <sup>*5</sup> [kVA]	114	140	165	199	248	271	347	436	489	547	611	773	871	-	-
	Single phase input	Voltage, frequency	Single-phase, 380 to 440 V, 50 Hz Single-phase, 380 to 480 V, 60 Hz														
		Voltage, frequency variations	Voltage: +10 to -10% , Frequency: +5 to -5%														
		Input current with DCR	132	158	188	226	283	309	392	492	558	633	717	878	1060	-	-
		Required capacity with DCR <sup>*5</sup> [kVA]	61	73	87	105	130	143	181	227	257	291	330	404	488	-	-
Braking Torque <sup>*6</sup> [%]	7 to 12%																
Braking transistor	-																
DC reactor (DCR)	As standard *7																
KEY PAD	Multi-function keypad as standard, Remote keypad with USB (Option)																
Applicable safety standards	UL508C, C22.2 No.14, EN61800-5-1:2007																
Enclosure (IEC60529)	IP00, UL open type , NEMA1(Optional)																
Cooling method	Fan cooling																
Weight/Mass [lbs(kg)]	93 (42)	137 (62)	141 (64)	207 (94)	216 (98)	284 (129)	309 (140)	540 (245)	540 (245)	805 (365)	805 (365)	1170 (530)	1170 (530)	-	-		

(\*1) Fuji 4-pole standard motor

(\*2) Rated capacity is calculated by assuming the output rated voltage as 230 V for 230 V series and 460 V for 460 V series.

(\*3) Output voltage cannot exceed the power supply voltage. At single-phase input use, the output voltage may be lower than three-phase input.

(\*4) Voltage unbalance [%] = (Max. voltage [V] - Min. voltage [V])/Three-phase average voltage [V]×67(See IEC61800-3.)

If this value is 2 to 3%, use an optional AC reactor (ACR).

(\*5) Required when a DC reactor (DCR) is used.

(\*6) Without external braking resistor condition.Average braking torque obtained by use of a motor. (Varies with the efficiency of the motor.)

(\*7) For Inverters of 100HP or above , the DC reactor is provided as separate standard component. Be sure to connect it to those inverters.



## 2. Common specifications

Item		Specifications	Remarks
Output	Setting range	Maximum frequency	25 to 500 Hz (HD mode, V/f control *1,*2,*3) 25 to 200 Hz (HD mode, V/f control w/PG/vector control w/PG*4,*5,*7) 25 to 120 Hz (HD mode, sensorless vector control *6, LD and MD mode, various controls,*1 to 7)
		Base frequency	25 to 500 Hz variable setting (LD (FRN007G1□ or above) and MD mode : 120Hz)
		Starting frequency	0.1 to 60.0 Hz variable setting (sensorless vector control*6/ vector control w/PG, 0.0 Hz for *7)
		Carrier frequency	<ul style="list-style-type: none"> <li>• 0.75 to 16 kHz variable setting (HD mode: FRNF50 to 100G1□, LD mode:FRNF50 to 040G1□)</li> <li>• 0.75 to 10 kHz variable setting (HD mode: FRN125 to 800G1□, LD mode: FRN050 to 100G1□)</li> <li>• 0.75 to 6 kHz variable setting (HD mode: FRN900 to 1000G1□, LD mode: FRN125 to 900G1□)</li> <li>• 0.75 to 4 kHz variable setting ( LD mode: FRN1000G1□)</li> <li>• 0.75 to 2kHz variable setting (MD mode:FRN150 to 800G1□)</li> </ul> NOTE: Frequency drops automatically to protect the inverter depending on environmental temperature and output current. (This auto drop function can be canceled.)
	Output frequency Accuracy (Stability)	<ul style="list-style-type: none"> <li>• Analog setting: ±0.2% of max. frequency (at 25 ±10 °C)*1</li> <li>• Digital setting: ±0.01% of max. frequency (at -10 to +50 °C)</li> </ul>	
	Setting resolution	<ul style="list-style-type: none"> <li>• Analog setting : Analog setting: 1/3000 of max. frequency (1/1500 with V2 input) The resolution can be set in the function code. (0.01 to 500Hz)</li> <li>• Keypad setting: 0.01Hz (99.99Hz or less), 0.1Hz (100.0 to 500Hz)</li> <li>• Link setting : 1/20000 of max. frequency or 0.01 Hz (fixed)</li> </ul>	
Speed control range	Speed control range	<ul style="list-style-type: none"> <li>•Min. speed: Base speed 1:1500 (4P 1r/min to 1500r/min) *7</li> <li>•Min. speed: Base speed 1:200 (4P 7.5r/min to 1500r/min) *6</li> <li>•Min. speed: Base speed 1:100 1:200 (4P 15r/min to 1500r/min, 1024p/r) *4, *5</li> <li>•Min. speed: Base speed 1:4 *7</li> <li>•Min. speed: Base speed 1:2 *4, *5, *6</li> </ul>	
	Speed control accuracy	<ul style="list-style-type: none"> <li>•Analog setting: ±0.2% of max. frequency (at 25±10°C) *4, *5, *7</li> <li>•Digital setting: ±0.01% of max. frequency (at -10 to +50°C)</li> <li>•Analog setting: ±0.5% or below of base speed (at 25±10°C) *6</li> <li>•Digital setting: ±0.5% or below of base speed (at -10 to +50°C)</li> </ul>	
	Control method	<ul style="list-style-type: none"> <li>•V/f control *1</li> <li>•Dynamic torque vector control *2</li> <li>•V/f control, the slip compensation is available. *3</li> <li>•V/f control with speed sensor (with an optional PG interface card mounted) *4</li> <li>•Dynamic torque vector control with speed sensor (with an optional PG interface card mounted) *5</li> <li>•Vector control without speed sensor *6</li> <li>•Vector control with speed sensor (with an optional PG interface card mounted) *7</li> </ul>	
Control	Voltage/freq. characteristic	230 V series	<ul style="list-style-type: none"> <li>•Base frequency and max. output frequency can be set to 80 to 240V in common.</li> <li>•The AVR control ON/OFF can be selected. *1, *4</li> <li>•Non-linear V/f setting (3 points): Free voltage (0 to 240V) and frequency (0 to 500Hz) can be set. *1, *4</li> </ul>
		460 V series	<ul style="list-style-type: none"> <li>•Base frequency and max. output frequency can be set to 160 to 500V in common.</li> <li>•The AVR control ON/OFF can be selected. *1, *4</li> <li>•Non-linear V/f setting (3 points): Free voltage (0 to 500V) and frequency (0 to 500Hz) can be set. *1, *4</li> </ul>
	Torque boost	<ul style="list-style-type: none"> <li>• Auto torque boost (for constant torque load) *1 to *4</li> <li>•Manual torque boost: Desired torque boost (0.0 to 20.0%) can be set. *1,*4</li> <li>•Select application load with function code F37. (Variable torque load or constant torque load) *1,*4</li> </ul>	
	Starting torque (HD mode)	<ul style="list-style-type: none"> <li>•FRN040G1□ or below: 200% or higher, FRN050G1□ or above: 180% or higher/set frequency: 0.3Hz *6</li> <li>•FRN040G1□ or below: 200% or higher, FRN050G1□ or above: 180% or higher/set frequency: 0.3Hz :Base frequency 50Hz, slip compensation and auto torque boost operation *1 to*4</li> </ul>	
	Start/stop operation	<ul style="list-style-type: none"> <li>•<b>Keypad (Option)</b></li> <li>•Remote keypad: Start and stop with RUN and STOP keys</li> <li>•Multi-function keypad: Start and stop with FWD, REV, and STOP keys</li> </ul> External signals (digital inputs): Forward (Reverse) rotation, stop command (capable of 3-wire operation), coast-to-stop command, external alarm, alarm reset, etc.	*8
	Link operation: Operation through RS-485 or field bus (option) communications, or USB *8(provided in remote keypad )		
	Switching operation command: Remote/Local switching, link switching		

Item	Specifications	Remarks	
Control	Enable input(Safety stop function)	Opening the circuit between terminals [EN] and [PLC] stops the inverter's output transistor (coast-to-stop). (Compliant with EN954-1 Cat.3)	
	Frequency setting	<ul style="list-style-type: none"> <li>• <b>Keypad (Option)</b> : Can be set with UP and DOWN keys *8</li> <li>• External Volume : Can be Set with external potentiometer (1 to 5kΩ 1/2W)</li> <li>• Analog input : 0 to ±10 VDC (±5 VDC)/0 to ±100% (Terminals [12] and [V2]) 0 to +10 VDC (+5 VDC)/0 to +100% (Terminals [12] and [V2]) +4 to +20 mA DC/0 to 100% (Terminal [C1])</li> <li>• UP/DOWN operation : Frequency can be increased or decreased while the digital input signal is ON.</li> <li>• Multi-frequency : Selectable from 16 steps (step 0 to 15)</li> <li>• Digital signal : 16bit parallel (binary, BCD)</li> <li>• Link operation : Frequency can be set through RS-485 (Standard setting)</li> <li>• Switching frequency setting : Frequency setting can be switched (2 settings) with external signal (digital input). Remote/local switching, link switching</li> <li>• Auxiliary frequency setting : Terminal [12], [C1], or [V2] input can be selected respectively as an additional input.</li> <li>• Operation at a specified ratio : The ratio can be set by analog input signal.</li> <li>• Inverse operation : The setting "0 to +10V DC/0 to 100%" can be switched to "+10 to 0V DC/0 to 100%" by external command. : The setting "4 to +20mA DC/0 to 100%" can be switched to "+2</li> <li>• Pulse train input : Pulse input = X7 terminal, rotational direction = general terminal Complementary output: Max. 100kHz, Open collector output: Max. 30kHz</li> <li>• Pulse train input : PG interface option CW/CCW pulse, pulse + rotational direction Complementary output: Max. 100kHz, Open collector output: Max. 25kHz</li> </ul>	"DC+1 to +5V" can be adjusted with bias and analog input gain
	Acceleration/deceleration time	<ul style="list-style-type: none"> <li>• Setting range: From 0.00 to 6000 s</li> <li>• Switch: The four types of accel./decel. time can be set or selected individually (switchable during operation).</li> <li>• Acceleration/deceleration pattern: Linear accel./decel., S-shape accel./decel. (weak, free, (strong)), curvilinear accel./decel. (accel./decel. max. capacity of constant output)</li> <li>• Deceleration mode (coast-to-stop): Coast-to-stop at the operation command OFF.</li> <li>• Forcible stop decel. time: Deceleration stop by the forcible stop (STOP)</li> <li>• Auto tuning by shortest accel./decel. mode and optimal accel./decel. Mode</li> </ul>	
	Frequency limiter (Upper limit and lower limit frequencies)	<ul style="list-style-type: none"> <li>• Both upper and lower limit frequencies can be variably set in hertz.</li> <li>• It is possible to choose the operation done when the set frequency drops below the lower limit from between continuous operation at lower limit frequency and operation stop.</li> </ul>	
	Bias frequency	<ul style="list-style-type: none"> <li>• Bias of set reference frequency and PID command can be independently set (setting range: 0 to ±100%).</li> </ul>	
	Analog input	<ul style="list-style-type: none"> <li>• Gain : Setting in the range from 0 to 200%</li> <li>• Off-set : Setting in the range from -5.0 to +5.0%</li> <li>• Filter : Setting in the range from 0.00s to 5.00s</li> </ul>	
	Jump frequency	<ul style="list-style-type: none"> <li>• Actuation points (3 points) and their common jump widths (0 to 30.0Hz) can be set.</li> </ul>	
	Jogging operation	<ul style="list-style-type: none"> <li>• Operation with RUN key (remote keypad), FWD, or REV key (multifunction keypad), or digital contact input, FWD, or REV (Exclusive accel./decel time setting, exclusive frequency setting)</li> </ul>	
	Auto-restart after momentary power failure	<ul style="list-style-type: none"> <li>• Trip at power failure: The inverter trips immediately after power failure.</li> <li>• Trip at power recovery: Coast-to-stop at power failure and trip at power recovery</li> <li>• Deceleration stop: Deceleration stop at power failure, and trip after stoppage</li> <li>• Continuous operation: Operation is continued using the load inertia energy.</li> <li>• Start at the frequency selected before momentary stop: Coast-to-stop at power failure and start after power recovery at the frequency selected before momentary stop. *1 to *3</li> <li>• Start at starting frequency: Coast-to-stop at power failure and start at the starting frequency after power recovery. *1 to *3</li> </ul>	
	Current limit by hardware	<ul style="list-style-type: none"> <li>• Limiting the current by hardware to prevent overcurrent trip due to sharp load change or momentary power failure which cannot be controlled by software current limit (This function can be cancelled.)</li> </ul>	
	Operation by commercial power supply	<ul style="list-style-type: none"> <li>• With commercial power selection command, the inverter outputs 50/60Hz (SW50, SW60). *1 to *3</li> <li>• The inverter has the commercial power supply selection sequence.</li> </ul>	
	Slip compensation	<ul style="list-style-type: none"> <li>• Compensates for decrease in speed according to the load. *1 to *3</li> </ul>	
	Droop control	<ul style="list-style-type: none"> <li>• Decrease the speed according to the load torque.</li> </ul>	
	Torque limiter	<ul style="list-style-type: none"> <li>• Switchable between 1st or 2nd torque limit values</li> <li>• Torque limit, torque current limit, and power limit are set for each quadrant. *6, *7</li> <li>• Analog torque limit input</li> </ul>	
	Current control (software current limit)	<ul style="list-style-type: none"> <li>• Automatically reduces the frequency so that the output current becomes lower than the preset operation level. *1 to *5</li> </ul>	

	Item	Specifications	Remarks
Control	PID control	<ul style="list-style-type: none"> <li>• PID adjuster for process control and that for dancer control</li> <li>• Switchable between forward and reverse operations</li> <li>• Low liquid level stop function (pressurized operation possible before low liquid level stop)</li> <li>• PID command: Keypad, analog input (from terminals [12], C1, V2), RS-485 communications</li> <li>• PID feedback value: Analog input (from terminals [12], C1, V2)</li> <li>• Alarm output (absolute value alarm, deviation alarm)</li> <li>• PID output limiter</li> <li>• Integration reset/ho</li> </ul>	
	Auto search for idling motor speed	<ul style="list-style-type: none"> <li>• Estimates the speed of the motor running under no load and starts the motor without stopping it. (Motor electric constant needs tuning: Offline tuning) *1 to *3 and *6</li> </ul>	
	Automatic deceleration	<ul style="list-style-type: none"> <li>•If the DC link bus voltage or calculated torque exceeds the automatic deceleration level during deceleration, the inverter automatically prolongs the deceleration time to avoid overvoltage trip. (It is possible to select forcible deceleration actuated wh</li> <li>•If the calculated torque exceeds automatic deceleration level during constant speed operation, the inverter avoids overvoltage trip by increasing the frequency.</li> </ul>	
	Deceleration characteristic (improving braking ability)	<ul style="list-style-type: none"> <li>•The motor loss is increased during deceleration to reduce the regenerative energy in the inverter to avoid overvoltage trip. *1, *4</li> </ul>	
	Automatic energy saving operation	<ul style="list-style-type: none"> <li>• The output voltage is controlled to minimize the total sum of the motor loss and inverter loss at a constant speed. (With digital input signal, automatic energy saving mode can be turned ON or OFF by an external device.)</li> </ul>	
	Overload prevention control	<ul style="list-style-type: none"> <li>•If the ambient temperature or IGBT joint temperature increases due to overload, the inverter lowers the output frequency to avoid overload.</li> </ul>	
	Off-line tuning	<ul style="list-style-type: none"> <li>•Rotary type and non-rotary type are available for tuning the motor constant.</li> </ul>	
	On-line tuning	<ul style="list-style-type: none"> <li>•Used as a motor constant for compensating the temperature change</li> </ul>	
	Cooling fan ON/OFF control	<ul style="list-style-type: none"> <li>• Detects inverter internal temperature of the inverter and stops the cooling fan when the temperature is low.</li> <li>•The fan control signal can be output to an external device.</li> </ul>	
	Setting 2nd to 4th motors	<ul style="list-style-type: none"> <li>•Switchable among the four motors</li> <li>•Code data for four kinds of specific functions can be switched (even during operation). It is possible to set the base frequency, rated current, torque boost, and electronic thermal slip compensation as the data for 1st to 4th motors.</li> </ul>	
	Universal DI	<ul style="list-style-type: none"> <li>•The status of external digital signal connected with the universal digital input terminal is transferred to the host controller.</li> </ul>	
	Universal DO	<ul style="list-style-type: none"> <li>•Digital command signal from the host controller is output to the universal digital output terminal.</li> </ul>	
	Universal AO	<ul style="list-style-type: none"> <li>•The analog command signal from the host controller is output to the analog output terminal.</li> </ul>	
	Overload stop function	<ul style="list-style-type: none"> <li>•When the torque or the current exceeds the set value, the inverter slows down and stop or coast-to-stop the motor. When the motor is stopped by hitting, the inverter controls the current to secure the holding torque. *1 to *5</li> </ul>	
	Speed control	<ul style="list-style-type: none"> <li>•Notch filter for vibration control, vibration suppressing observer. *7</li> <li>•Estimates the GD<sup>2</sup> value applied to the motor shaft from the load, and automatically controls the ASR system constant. *6 and *7</li> </ul>	
	Preliminary excitation	<ul style="list-style-type: none"> <li>•Excitation is carried out to create the motor flux before starting the motor. *6 and*7</li> </ul>	
	Zero speed control	<ul style="list-style-type: none"> <li>•The motor speed is held to zero by forcibly zeroing the speed command. *7</li> </ul>	
	Servo lock	<ul style="list-style-type: none"> <li>•Stops the inverter and holds the motor in stop position. *7</li> </ul>	
	Torque control *6, *7	<ul style="list-style-type: none"> <li>•Analog torque command input</li> <li>•Speed limit function is provided to prevent the motor from becoming out of control.</li> </ul>	
	Rotation direction control	<ul style="list-style-type: none"> <li>•Preventing reverse rotation</li> <li>•Preventing forward rotation</li> </ul>	
Preventing condensation in motor	<ul style="list-style-type: none"> <li>•When the inverter is stopped, current is automatically supplied to the motor to keep the motor warm and avoid condensation.</li> </ul>		
Customized logic interface	<ul style="list-style-type: none"> <li>•Available in 10 steps with the functions of 2-input, 1-output, logical operation, and timer function</li> </ul>		
Display <sup>8</sup>	Run/stop	<ul style="list-style-type: none"> <li>Speed monitor (set frequency, output frequency, motor speed, load shaft speed, line speed, and speed indication with percent)</li> <li>Output current [A], output voltage [V], calculated torque, input power [HP], PID reference value, PID feedback value, PID output</li> </ul>	
	Inverter life warning	<ul style="list-style-type: none"> <li>•Life judgment of the main circuit capacitor, electrolytic capacitor on printed circuit board, and cooling fan</li> <li>•Life warning information can be output to an external device.</li> <li>•Ambient temperature: 40° C, Load rate: inverter rated current 100% (LD type: 80%)</li> </ul>	
	Cumulative running hours	<ul style="list-style-type: none"> <li>•Displays the inverter cumulative running hours, integrated power, cumulative motor running hours, and the number of operation start times (of each motor).</li> <li>•Outputs the warning when the maintenance time or the number of start times has exceeded the preset</li> </ul>	
	Trip mode	<ul style="list-style-type: none"> <li>•Displays the cause of trip.</li> </ul>	
	Light-alarm	<ul style="list-style-type: none"> <li>•Shows the light-alarm display [L-AL].</li> </ul>	
	Running or trip mode	<ul style="list-style-type: none"> <li>•Trip history: Saves and displays the cause of the last four trips (with a code).</li> <li>•Also saves and displays the detailed data recorded on occurrence of the last four trips.</li> </ul>	

Item	Specifications	Remarks	
Overcurrent protection	• The inverter is stopped for protection against overcurrent.	OC1,OC2,OC3	
Short-circuit protection	• The inverter is stopped for protection against overcurrent caused by a short circuit in the output circuit.		
Ground fault protection	• The inverter is stopped for protection against overcurrent caused by a grounding fault in the output circuit. (FRN040G1□ or below)		
	• Detecting zero-phase current of output current, the inverter is stopped for protection against overcurrent caused by a grounding fault in the output circuit. (FRN050G1□ or above)	EF	
Overvoltage protection	• An excessive voltage (200V series: 400V DC, 400V series: 800V DC) in the DC link circuit is detected and the inverter is stopped. If an excessive voltage is applied by mistake, the protection can not be guaranteed.	OU1,OU2,OU3	
Undervoltage protection	• The voltage drop (200V series: 200V DC, 400V series: 400V DC) in the DC link circuit is detected to stop the inverter.	LU	
Input phase loss protection	• The input phase loss is detected to shut off the inverter output. This function protects the inverter. • When the load to be connected is small or DC REACTOR is connected a phase loss is not detected.	Lin	
Output phase loss detection	Detects breaks in inverter output wiring at the start of running and during running, stopping the inverter output.	OPL	
Overheat protection	• Stop the inverter output detecting excess cooling fan temperature in case of a cooling fan fault or overload.	OH1	
	• Stop the inverter output detecting a fault of inner agitating fan. (FRN075G1□-2U, FRN125G1□-4U or above)		
	• Stop the inverter output detecting inner temperature of the inverter unit for a cooling fan fault or overload.	OH3	
	• Protect the braking resistor from over heat by setting the braking resistor electronic thermal function.	dbH	
Overload protection	• Stop the inverter output detecting a cooling unit temperature of the inverter cooling fan and a switching element temperature calculated with the output current.	OLU	
External alarm input	• With the digital input signal (THR) opened, the inverter is stopped with an alarm.	OH2	
Fuse breaking	• Stop the inverter output detecting the fuse breaking of the main circuit in the inverter. (FRN125G1□-2U, FRN150G1□-4U or above)	FUS	
Charging circuit abnormality	• Stop the inverter output detecting the charge circuit abnormality in the inverter. (FRN060G1□-2U, FRN125G1□-4U or above)	PbF	
Brake transistor abnormality	• Stop the inverter detecting the brake transistor abnormality. (DB transistor built-in type only)	dbAL	
Over-speed protection *4 to *7	• Stop the inverter when the detected speed exceeds 120% of max. output frequency.	OS	
PG breakwire *4 *5 *7	• Stop the inverter detecting the PG breaking.	Pg	
Protective function Motor protection	Electronic thermal	• The inverter is stopped with an electronic thermal function set to protect the motor. Protects the general-purpose motor inverter over all frequency range.(The running level and thermal time constant (0.5 to 75.0 min) can be set.)	OL1 to OL4
	PTC thermistor	• A PTC thermistor input stops the inverter to protect the motor. Connect a PTC thermistor between terminal V2 and 11 and set the switch on control print board and the function code.	OH4
	NTC thermistor	• The NTC thermistor detects a motor temperature. Connect a NTC thermistor between terminal V2 and 11 and set the switch on control print board and the function code.	
	NTC thermistor broken	• Stop the inverter output detecting the built-in motor NTC breaking.	nrb
	Overload early warning	• Warning signal is output at the predetermined level before stopping the inverter with electronic thermal function.	-
Memory error	• Data is checked upon power-on and data writing to detect any fault in the memory and to stop the inverter if any.	Er1	
Keypad communications error detection	• The keypad is used to detect a communication fault between the keypad and inverter main body during operation and to stop the inverter.	Er2	
CPU error	• Stop the invert detecting a CPU error or LSI error caused by noise.	Er3	
Option communications error	• When each option is used, a fault of communication with the inverter main body is detected to stop the inverter.	Er4	
Option error	• When each option is used, the option detects a fault to stop the inverter.	Er5	
Operation error	• STOP key priority Pressing the STOP key on the keypad or entering the digital input signal will forcibly decelerate and stop the motor even if the operation command through signal input or communication is selected. Er6 will be displayed after the stop.	Er6	
	• Start check: If the running command is being ordered when switching the running command method from power-on, alarm reset, or the linked operation, the operation starts suddenly. This function bans running and displays Er6.		
Tuning error	• Stop the inverter output when tuning failure, interruption, or any fault as a result of tuning is detected during tuning for motor constant.	Er7	
RS-485 communicationserror (port1)	• When the connection port of the keypad connected via RS485 communication port to detect a communication error, the inverter is stopped and displays an error.	Er8	
Speed deviation excess *4 to *7	• Stop the inverter output when the speed deviation exceeds the specified value (difference between speed command and feedback).	ErE	
Data save error upon undervoltage	• When the undervoltage protection function works, an alarm is displayed if the data is not properly saved.	ErF	
RS-485 communicationserror (port2)	• Stop the inverter output detecting the communication error between the inverter main unit and a mate when the RS-485 connection port of the touch panel is used to configure the network.	ErP	
Hardware error	• Stop the inverter output detecting the communication error between the inverter main unit and a mate when the RS-485 connection port of the touch panel is used to configure the network..	ErH	
Simulation error	• Simulated alarm is output by the keypad operation.	Err	
EN Circuit Error	• The circuit to detect EN terminal status is broken (Single fault) *9	ECF	



### 3. Terminal functions

Classification	Symbol	Name	Functions	Remarks
Main circuit terminals	L1/R, L2/S L3/T	Main circuit power inputs	Connect the three-phase input power lines.	
	R0, T0	Auxiliary power input for the control circuit	Connect AC power lines.	
	R1, T1	Auxiliary power input for the fans	Normally, no need to use these terminals. Use these terminals for an auxiliary power input of the fans in a power system using a power regenerative PWM converter.	(FRN060G1□-2U or above) (FRN125G1□-4U or above)
	U, V, W	Inverter outputs	Connect a three-phase motor.	
	P(+), P1	DC reactor connection	Connect a DC reactor (DCR).	
	P(+), N(-)	DC link bus	Terminal for DC bus link system.	
	P(+), DB	Braking resistor	Connect an external braking resistor (option).	
⊕ G	Grounding for inverter	Grounding terminals for the inverter.		
Analog input	[13]	Power supply for the potentiometer	Power supply (+10 VDC) for frequency command potentiometer (Variable resistor: 1 to 5kΩ) The potentiometer of 1/2 W rating or more should be connected. (10 VDC, 10 mADC max.)	
	[12]	Analog setting voltage input	• External input voltage to be used as a frequency command. 0 to +10 VDC/ 0% to 100% (0 to +5 VDC/ 0% to 100%) 0 to ±10 VDC/ 0% to ±100% (0 to ±5 VDC/ 0% to ±100%)	Input impedance: 22k Ω Maximum input ±15 VDC
		(Inverse operation)	• +10 to 0 VDC/ 0 to 100%	
		(PID control)	Used as PID command value or PID feedback signal.	Gain: 200%
		(Auxiliary frequency setting)	• Used as additional auxiliary setting to various frequency settings.	Offset: ±5%
		(Gain setting)	• Used as gain for the frequency command. 0% to 100% for 0 to 10 V	Setting filter: 5 s
		(Torque limit value)	• Analog torque limit value	
	(Torque command)	• Analog torque command value <sup>67</sup>		
	(Analog input monitor)	• Enables peripheral analog signals to be displayed on the keypad. (Display coefficient valid)		
	[C1]	Analog setting current input	• External input voltage to be used as a frequency command. 4 to 20 mADC/ 0% to 100%	Input impedance: 250 Ω Maximum input 30 mADC
(Inverse operation)		• 20 to 4 mADC/ 0% to 100%		
(PID control)		Used as PID command value or PID feedback signal.	Gain: 200%	
(PTC/NTC thermistor connection)		• Connect a PTC/NTC thermistor for motor protection. (Switchable)	Offset: ±5%	
(Auxiliary frequency setting)		• Used as additional auxiliary setting to various frequency settings.	Setting filter: 5 s	
(Gain setting)		• Used as gain for the frequency command. 0% to 100% for 4 to 20 mA		
(Torque limit value)	• Analog torque limit value			
(Torque command)	• Analog torque command value <sup>67</sup>			
(Analog input monitor)	• Enables peripheral analog signals to be displayed on the keypad. (Display coefficient valid)			
[V2]	Analog setting voltage input	• External input voltage to be used as a frequency command. 0 to +10 VDC/ 0 to 100% (0 to +5 VDC/ 0 to 100%) 0 to ±10 VDC/ 0 to ±100% (0 to ±5 VDC/ 0 to ±100%)	Input impedance: 22k Ω Maximum input ±15 VDC	
	(Inverse operation)	• +10 to 0 VDC/ 0 to 100%		
	(PID control)	Used as PID command value or PID feedback signal.	Gain: 200%	
	(Auxiliary frequency setting)	• Used as additional auxiliary setting to various frequency settings.	Offset: ±5%	
	(Gain setting)	• Used as gain for the frequency command. 0% to 100% for 0 to 10 V	Setting filter: 5 s	
	(Torque limit value)	• Analog torque limit value		
(Torque command)	• Analog torque command value <sup>67</sup>			
(Analog input monitor)	• Enables peripheral analog signals to be displayed on the keypad. (Display coefficient valid)			
[11] (2 terminals)	Analog common	Common terminals for frequency command signals (12, 13, C1, V2, FM1, FM2).	These terminals are electrically isolated from terminals [CM]s and [CMY]s.	
Digital input	[X1]	Digital input 1	• The following functions can be assigned to terminals [X1] to [X7], [FWD], and [REV]. <Common functions>	Operation current at ON Source current: 2.5 to 5 mA Source current: 11 to 16 mA (terminal [X7])
	[X2]	Digital input 2		
	[X3]	Digital input 3		
	[X4]	Digital input 4	• SINK/SOURCE is changeable by using the internal slide switch. • These function codes may also switch the logic system between normal and negative to define how the inverter logic interprets either ON or OFF status of each terminal.	Voltage level: 2 V
	[X5]	Digital input 5		
	[X6]	Digital input 6		
	[X7]	Digital input 7	Terminal [X7] can receive a pulse rate input. (Using the SY disables [X7].)	Operation current at OFF Allowable leakage current: 0.5 mA or less Voltage: 22 to 27 V
	[FWD]	Run forward commands		
	[REV]	Run reverse commands		
[EN]	Enable Input	• This terminal stops output transistor (making coast-to-stop) when the terminal EN-PLC is turned off. This terminal is dedicated for source input.	Source current at Turn-on : 5-10mA	

Classification	Symbol	Name	Functions	Remarks
Digital input	[CM]	Digital input common	Common terminals for digital input signals.	This terminal is electrically isolated from terminals [CM]s and [11]s.
	[PLC] (2 terminals)	PLC signal power	Connect to PLC output signal power supply. This terminal also serves as 24 V power supply.	+24 V (22 to 27 V), Max. 100 mA
	(FWD)	Run forward	Turning the (FWD) ON runs the motor in the forward direction; turning it OFF decelerates it to a stop.	These terminal commands can be assigned only to terminals [FWD] and [REV]. The negative logic system never applies to those terminals.
	(REV)	Run reverse	Turning the (REV) ON runs the motor in the reverse direction; turning it OFF decelerates it to a stop.	Same as above.
	(SS1) (SS2) (SS4) (SS8)	Select multi-frequency	The combination of the ON/OFF states of digital input signals (SS1), (SS2), (SS4) and (SS8) provides 16 different frequency choices.	
	(RT1)	Select ACC/DEC time (2 steps)	The combination of the ON/OFF states of (RT1) and (RT2) provides four choices of acceleration/deceleration settings.	
	(RT2)	Select ACC/DEC time (4 steps)		
	(HLD)	Enable 3-wire operation	Used as a self-hold signal for 3-wire inverter operation. Turning the (HLD) ON self-holds the (FWD) or (REV) command; turning it OFF releases the self-holding.	
	(BX)	Coast to a stop	Turning the (BX) ON immediately shuts down the inverter output so that the motor coasts to a stop without issuing any alarms.	
	(RST)	Reset alarm	Turning the (RST) ON clears the alarm state.	Signal of 0.1 s or more
	(THR)	Enable external alarm trip	Turning the (THR) OFF immediately shuts down the inverter output so that the motor coasts to a stop, issuing OH2 if (ALM) is enabled.	
	(JOG)	Ready for jogging	Turning the (JOG) ON readies the inverter for jogging. Turning the (FWD) or (REV) ON starts jogging in the rotation direction specified by the jogging frequency.	
	(Hz2/Hz1)	Select frequency command 2/1	Turning the (Hz2/Hz1) ON selects Frequency command 2. (If the PID control is enabled, this terminal command switches the PID command.)	
	(M2)	Select motor 2	The combination of the ON/OFF states of (M2), (M3) and (M4) provides four choices of Motors 1 to 4. (Setting all of (M2), (M3) and (M4) OFF selects Motor 1.)	
	(M3)	Select motor 3		
	(M4)	Select motor 4		
	(DCBRK)	Enable DC braking	Turning the (DCBRK) ON activates DC braking.	
	(TL2/TL1)	Select torque limiter level	The (TL2/TL1) switches between torque limiters 1 and 2.	
	(SW50)	Switch to commercial power (50 Hz)	Turning the (SW50) OFF switches to commercial power, 50 Hz. *1~*3	
	(SW60)	Switch to commercial power (60 Hz)	Turning the (SW60) OFF switches to commercial power, 60 Hz. *1~*3	
	(UP)	UP (Increase output frequency)	While the (UP) is ON, the output frequency increases.	
	(DOWN)	DOWN (Decrease output frequency)	While the (UP) is ON, the output frequency decreases.	
	(WE-KP)	Enable data change with keypad	Only when the (WE-KP) is ON, function code data can be changed with the keypad.	
	(Hz/PID)	Cancel PID control	Turning the (Hz/PID) ON disables the PID control so that the inverter runs the motor with a reference frequency specified by any of the multi-frequency, keypad, analog input, etc.	
	(IVS)	Switch normal/inverse operation	The (INV) switches the output frequency control between normal (proportional to the input value) and inverse in PID process control and manual frequency command. Turning the (INV) ON selects the inverse operation.	
	(IL)	Interlock	In a configuration where a magnetic contactor (MC) is inserted between the inverter and motor, connecting the auxiliary contact to this terminal enables the input of the (IL) when a power failure occurs, activating the momentary power failure detection fu	
	(LE)	Enable communications link via RS-485 or field bus	Turning the (LE) ON gives priority to commands received via the RS-485 communications link or the field bus option.	
(U-DI)	Universal DI	Using the (U-DI) enables the inverter to monitor arbitrary digital input signals sent from the peripheral equipment, telling the signal status to the host.		
(STM)	Enable auto search for idling motor speed at starting	The (STM) enables auto search for idling motor speed at the start of operation.		
(STOP)	Force to stop	Turning the (STOP) OFF causes the motor to decelerate to a stop forcedly in accordance with the specified deceleration time.		

Classification	Symbol	Name	Functions	Remarks
Digital input	(PID-RST)	Reset PID integral and differential components	Turning the (PID-RST) ON resets PID integral and differential components.	
	(PID-HLD)	Hold PID integral component	Turning this terminal command ON holds the integral components of the PID processor.	
	(EXITE)	Pre-excitation	When this (EXITE) signal comes ON, preliminary excitation starts. <sup>6,7</sup>	
	(LOC)	Select local (keypad) operation	Turning the (LOC) ON gives priority to run/frequency commands entered from the keypad.	
	(DWP)	Protect motor from dew condensation	Turning the (DWP) ON supplies a DC current to the motor that is on halt, in order to generate heat, preventing dew condensation.	
	(ISW50)	Enable integrated sequence to switch to commercial power (50 Hz)	Turning the (ISW50) OFF switches inverter operation to commercial-power operation in accordance with the inverter internal switching sequence (for 50 Hz).	
	(ISW60)	Enable integrated sequence to switch to commercial power (60 Hz)	Turning the (ISW50) OFF switches inverter operation to commercial-power operation in accordance with the inverter internal switching sequence (for 60 Hz).	
	(OLS)	Enable/disable overload stop function	Turning (OLS) enables the overload stop function. <sup>1~5</sup>	
	(PIN)	Pulse train input	Frequency command by pulse rate input.	Available only on terminal [X7] (E07)
	(SIGN)	Pulse train sign	Rotational direction command for pulse rate input. OFF: Forward, ON: Reverse	Available only on terminal [X7] (E07)
	(CRUN-M1)	Count the run time of commercial power-driven motor 1	Turning the (CRUN-M1) ON accumulates the run time of motor 1 in commercial-power operation. (independent of run/stop and motor selected)	
	(CRUN-M2)	Count the run time of commercial power-driven motor 2	Turning the (CRUN-M2) ON accumulates the run time of motor 2 in commercial-power operation. (independent of run/stop and motor selected)	
	(CRUN-M3)	Count the run time of commercial power-driven motor 3	Turning the (CRUN-M3) ON accumulates the run time of motor 3 in commercial-power operation. (independent of run/stop and motor selected)	
	(CRUN-M4)	Count the run time of commercial power-driven motor 4	Turning the (CRUN-M4) ON accumulates the run time of motor 4 in commercial-power operation. (independent of run/stop and motor selected)	
	(DROOP)	Select droop control	Turning the(DROOP) ON enables the droop control.	
	(PG-CCL)	Cancel PG alarm	Turning the(PG-CCL) ON cancels PG alarm. <sup>4,5,7</sup>	
	(LOCK)	Servo-lock command	Turning the(LOCK) ON enables the servo-lock control. <sup>7</sup>	
(NONE)	No function	No function assigned. Can be used as a temporary input of the customized logic interface.		
Transistor output	(PLC)	Transistor output power	Transistor output load power. (24 VDC, 100 mA DC max.) (Note: Shared by the digital input PLC terminal.)	Short-circuit terminals [CM] and [CMY].
	[Y1]	Transistor output 1	Out of the following signals, the selected one will be issued. • These function codes may also switch the logic system between normal and negative to define how the inverter logic interprets either ON or OFF status of each terminal.	Maximum voltage 27 VDC Maximum current 50 mADC
	[Y2]	Transistor output 2	Applicable to SINK and SOURCE. (No switching is required.)	Leakage current
	[Y3]	Transistor output 3		0.1 mA or less
	[Y4]	Transistor output 4		ON voltage: Max. 2V (50 mA)
	[CMY]	Transistor output common	Common terminal for transistor output signal terminals.	This terminal is electrically isolated from terminals [CM]s and [1]s.
	(RUN)	Inverter running	This signal is ON when the inverter is running with the starting frequency or higher.	
	(RUN2)	Inverter output on	This signal is ON when the inverter is running with the starting frequency or higher or when the DC braking is activated.	
(DNZS)	Speed valid	This signal is turned ON when the speed command/actual speed exceeds the stop frequency; it is turned OFF when it is below the stop frequency. (Speed command and actual speed selectable.)		



Classification	Symbol	Name	Functions	Remarks
Transistor output	(FRUN)	Running forward	ON-signal is generated at forward rotation.	
	(RRUN)	Running reverse	ON-signal is generated at reverse rotation	
	(FAR)	Frequency (speed) arrival signal	ON-signal is generated when frequency / speed reaches at set-value.	
	(FAR3)	Frequency (speed) arrival signal 3	ON-signal is generated when frequency / speed reaches at set-value. When the run command is OFF, the frequency command is interpreted as zero and frequency arrival is judged under the premise.	
	(FDT)	Frequency (speed) detected	This output signal comes ON when the output frequency exceeds the frequency detection level, and it goes OFF when the output frequency drops below the "Frequency detection level - Hysteresis width."	
	(FDT2)	Frequency (speed) detected 2		
	(FDT3)	Frequency (speed) detected 3		
	(LU)	Undervoltage detected (Inverter stopped)	This signal is ON when the undervoltage protection function is activated so that the motor is in an abnormal stop state.	
	(B/D)	Torque polarity detected	This signal comes ON when the inverter is driving the motor; it comes OFF when the inverter is braking the motor or on halt.	
	(IOL)	Inverter output limiting	This signal comes ON when the inverter is activating the current limiter, torque limiter, or anti-regenerative control (automatic deceleration).	
	(IOL2)	Inverter output limiting with delay	This signal comes ON when the inverter has been activated the current limiter, torque limiter, or anti-regenerative control (automatic deceleration) for at least 20 ms.	
	(IPF)	Auto-restarting after momentary power failure	This signal is kept ON during the period from when the inverter shuts down its output due to a momentary power failure until the restart is completed.	
	(OL)	Motor overload early warning	This signal comes ON when the value calculated by the electronic thermal overload protection exceeds the predetermined detection level. (applicable to Motor 1 only)	
	(KP)	Keypad operation enabled	This signal is ON when the inverter is in keypad operation.	
	(RDY)	Inverter ready to run	This signal comes ON when the inverter is ready to run.	
	(SW88)	Switch motor drive source between commercial power and inverter output (For MC on commercial line)	This controls the magnetic contactor located at the commercial power line side, for switching the motor drive source from the commercial power line to inverter output.	
	(SW52-2)	Switch motor drive source between commercial power and inverter output (For secondary side)	This controls the magnetic contactor located at the inverter output side (secondary side), for switching the motor drive source from the commercial power line to inverter output.	
	(SW52-1)	Switch motor drive source between commercial power and inverter output (For primary side)	This controls the magnetic contactor located at the inverter input side (primary side), for switching the motor drive source from the commercial power line to inverter output.	
	(SWM1)	Motor 1 selected	This signal comes ON when motor 1 is selected.	
	(SWM2)	Motor 2 selected	This signal comes ON when motor 2 is selected.	
	(SWM3)	Motor 3 selected	This signal comes ON when motor 3 is selected.	
	(SWM4)	Motor 4 selected	This signal comes ON when motor 4 is selected.	
	(AX)	Select AX terminal function (For MC on primary side)	This signal controls the magnetic contactor located at the inverter input side (primary side).	
	(FAN)	Cooling fan in operation	This signal tells the ON/OFF state of the cooling fan.	
	(TRY)	Auto-resetting	This output signal comes ON when auto-resetting is in progress.	
	(U-DO)	Universal DO	This signal commands a peripheral apparatus according to signal sent from the host controller.	
	(ID)	Current detected	This signal comes ON when the output current of the inverter has exceeded the detection level for the time longer than the specified timer period.	
	(ID2)	Current detected 2		
	(ID3)	Current detected 3		
	(TD1)	Torque detected 1	This signal comes ON when the output torque of the inverter has exceeded the detection level for the time longer than the specified timer period.	
	(TD2)	Torque detected 2		
	(OH)	Heat sink overheat early warning	This outputs a heat sink overheat early warning before an overheat trip actually happens. It is also used to detect an internal air circulation fan failure. (Applicable to inverters with FRN075G1□-2U, FRN125G1□-4U or above.)	

Classification	Symbol	Name	Functions	Remarks
Transistor output	(LIFE)	Lifetime alarm	This outputs a service lifetime alarm according to the internal lifetime criteria. It is also used to detect an internal air circulation fan failure. (Applicable to inverters with FRN075G1□-2U, FRN125G1□-4U or above.)	
	(PID-ALM)	PID alarm	This outputs an absolute-value alarm and deviation alarm when the PID control is enabled.	
	(PID-CTL)	Under PID control	This signal comes ON when the PID control is enabled.	
	(PID-STP)	Motor stopped due to slow flowrate under PID control	This signal is ON when the inverter is in a stopped state by the slow flowrate stopping function under the PID control. (The inverter is stopped even if a run command is entered.)	
	(REF OFF)	Reference loss detected	This signal comes ON when an analog frequency command is missed due to wire breaks.	
	(IDL)	Low current detected	This signal comes ON when the current has been below the preset current detection level for the time longer than the specified timer period.	
	(U-TL)	Low output torque detected	This signal comes ON when the torque value has been below the preset detection level for the time longer than the specified timer period.	
	(OLP)	Overload prevention control	This output signal comes ON when the overload prevention control is activated.	
	(RMT)	In remote operation	This signal comes ON when the inverter is in the remote mode.	
	(BRKS)	Brake signal	Signal for Brake Control. Turn ON when the brake is released.	
	(MNT)	Maintenance timer	Alarm signal is generated when time passes or start-up exceeds over the preset value.	
	(THM)	Motor overheat detected by thermistor	This signal comes ON when the motor overheat is detected with the PTC/NTC thermistor.	
	(C1OFF)	Terminal [C1] wire break	When Input current to C1 terminal become less than 2mA, this is interpreted as wire brake and then ON-signal is generated.	
	(DSAG)	Speed agreement	This output signal comes ON when the difference between the detected speed and the commanded speed (frequency) has been within the specified range for the time specified by the agreement timer.	
	(PG-ERR)	PG error detected	Speed Deflection is greater than the certain value. ON-signal is generated.	
	(DECF)	Enable circuit failure detected	This signal comes ON when the circuit detecting the status of [EN] terminal is defective. (at single failure)	
	(ENOFF)	Enable input OFF	On-signal is generated when Enabe Input is turned off.	
	(DBAL)	Braking transistor broken	This signal comes ON when the DBTr defective is detected.	
(PSET)	Positioning completion signal	This signal comes ON when the inverter has been servo-locked so that the motor is held within the positioning completion range.		
(L-ALM)	Light alarm	When Alarm or warning, which is set as "light failure", is generated, inverter indicates "Light failure" on the display and generates this light failure signal.		
(ALM)	Alarm output (for any alarm)	This is an alarm relay output as a transistor output.		
Relay output	[Y5A], [Y5C]	General purpose relay output	<ul style="list-style-type: none"> <li>As a general-purpose relay output, the same functions as Y1 to Y4 can be assigned.</li> <li>The logic value is switchable between "[Y5A] and [Y5C] are excited" and "non-excited."</li> </ul>	Contact rating: 250 VAC, 0.3 A cosφ=0.3
	[30A], [30B], [30C]	Alarm relay output (for any error)	<ul style="list-style-type: none"> <li>This outputs a non-voltage contact signal (1c) when the inverter is stopped with the protective function.</li> <li>As a general-purpose relay output, the same functions as Y1 to Y4 can be assigned.</li> <li>The logic value is switchable between "[Y5A] and [Y5C] are excited" and "non-excited."</li> </ul>	48 VDC, 0.5A

Classification	Symbol	Name	Functions	Remarks
Analog output	[FM1] [FM2]	Analog monitor 1 Analog monitor 2	<p>The output can be either analog DC voltage (0 to 10 V) or analog DC current (4 to 20 mA).</p> <p>Any one of the following items can be output with the selected analog form.</p> <ul style="list-style-type: none"> <li>• Output frequency (before slip compensation, after slip compensation)</li> <li>• Output current</li> <li>• Output voltage</li> <li>• Output torque</li> <li>• Load factor</li> <li>• Input power</li> <li>• PID feedback amount</li> <li>• DC link bus voltage</li> <li>• Universal AO</li> <li>• Motor output</li> <li>• Analog output test</li> <li>• PID command</li> <li>• PID output</li> <li>• Speed detection (PG feedback value)</li> </ul> <p>*When the terminal is outputting 0 to 10 VDC, it is capable of driving up to two meters with 10k<math>\Omega</math> impedance.</p> <p>*When the terminal is outputting current, it is capable of connecting a maximum of 500<math>\Omega</math> to the meter.</p> <p>Adjustable gain range: 0% to 300%</p>	
	[11]	Analog common		
Communication	RJ-45 connector for the keypad	RS-485 communications port 1	<p>Out of the following protocols, the desired one can be selected.</p> <ul style="list-style-type: none"> <li>• Modbus RTU</li> <li>• Fuji general-purpose inverter protocol</li> <li>• FRENIC Loader protocol (SX)</li> </ul>	With power supply to the keypad
	[DX+]/[DX-]/[SD]	RS-485 communications port 2 (Terminal on control PCB)	<ul style="list-style-type: none"> <li>• Modbus RTU</li> <li>• Fuji general-purpose inverter protocol</li> </ul>	
	USB connector	USB port (On the keypad)	A USB port connector (Mini-B) that connects an inverter to a personal computer. FRENIC Loader.	Mounted on Remote Keypad (option)

\*1 Effective function in V/f control

\*2 Effective function in dynamic torque vector control

\*3 Effective function when the slip compensation is made active under V/f control

\*4 Effective function under the V/f control with speed sensor (PG option is necessary.)

\*5 Effective function in dynamic torque vector control with speed sensor. (PG option is necessary.)

\*6 Effective function in vector control without speed sensor

\*7 Effective function in vector control with speed sensor (PG option is necessary.)

**Standard models**

Inverter type		Dimensions										ØA				
FRN_	GIS-2U/4U	inch (mm)														
230 V	460 V	W	W1	W2	H	H1	H2	D	D1	D2	D3					
0.5	0.5	4.33 (110)	3.78 (96)	0.24 (6)	10.24 (260)	9.69 (246)	0.28 (7)	5.2 (132)	4.45 (113)	0.75 (19)	0.12 (3)	0.24 (6)				
1	1	5.91 (150)	5.35 (136)					9.37 (238)		10.04 (255)			4.43 (113)	5.71 (145)	1.26 (32)	
2	2															
3	3															
5	5															
7.5	7.5	8.66 (220)	7.72 (196)	0.39 (10)	21.65 (550)	20.87 (530)	0.43 (11)	7.68 (195)	4.13 (105)	3.54 (90)	0.39 (10)					
10	10															
15	15															
20	20															
25	25															
30	30	9.84 (250)	8.9 (226)	15.75 (400)	14.88 (378)	0.47 (12)	10.63 (270)	4.53 (115)	6.1 (155)							
40	40															
50	50	12.6 (320)	9.45 (240)							24.21 (615)	23.43 (595)	26.57 (675)	25.79 (655)			
60	75															
—	100	13.98 (355)	10.83 (275)	29.13 (740)	28.35 (720)	11.22 (285)	5.71 (145)	5.51 (140)								
75	125															
100	125															
125	—															
150	—	20.87 (530)	16.93 (430)	0.59 (15)	34.65 (880)	33.46 (850)	0.61 (15.5)	14.17 (360)	7.09 (180)	7.09 (180)	0.16 (4)					
—	150															
—	200	20.87 (530)	16.93 (430)									29.13 (740)	27.95 (710)	12.4 (315)	5.31 (135)	
—	250															
—	300	26.77 (680)	11.42 (290)									39.37 (1000)	38.19 (970)	14.17 (360)	7.09 (180)	7.09 (180)
—	350															
—	450															
—	500															
—	600	55.12 (1400)	53.94 (1370)									17.32 (440)	10.24 (260)	0.25 (6.4)		
—	700															
—	800															
—	900															
—	1000	61.02 (1550)	59.84 (1520)	19.69 (500)	12.33 (313.2)	7.35 (186.8)										
—	1000															

40 HP or below

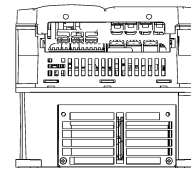
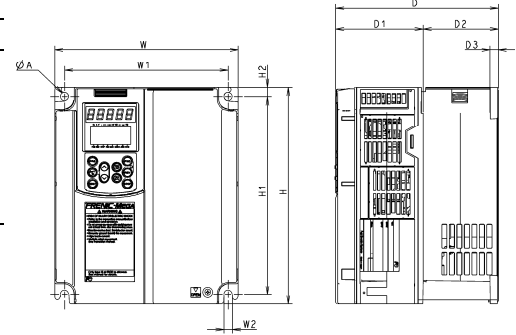

50 HP or above

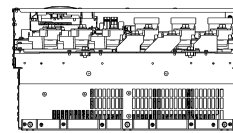
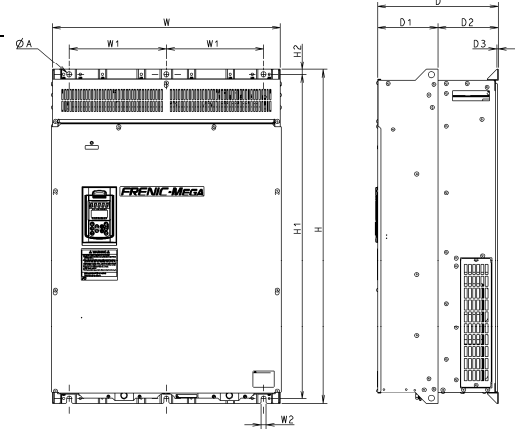

**Standard models with NEMA1 kit (option)**

Inverter type FRN__G1S-2U/4U		Dimensions inch (mm)		
230 V	460 V	W	H	D
0.5	0.5	4.45 (113)	12.2 (310)	5.26 (133.5)
1	1			5.76 (146.3)
2	2	5.87 (149)		5.76 (146.2)
3	3		8.66 (220)	7.68 (195)
5	5			
7.5	7.5	9.84 (250)	13.24 (336.2)	
10	10		19.27 (490)	
15	15			
20	20	19.27 (490)	22.05 (560)	10.63 (270)
25	25		14.11 (358.4)	
30	30			
40	—	14.11 (358.4)	26.97 (685)	10.63 (270)
—	40		32.28 (820)	
50	50	12.73 (323.4)	26.97 (685)	10.04 (255)
60	—	14.11 (358.4)	29.92 (760)	10.63 (270)
—	60	12.73 (323.4)	26.97 (685)	10.04 (255)
75	—	14.11 (358.4)	34.84 (885)	10.63 (270)
—	75		29.92 (760)	
100	—		34.84 (885)	
—	100		32.28 (820)	
125	—	21 (533.4)	37.8 (960)	11.22 (285)
—	125	14.11 (358.4)	34.84 (885)	10.63 (270)
150	—	26.91 (683.4)	46.46 (1180)	14.17 (360)
—	150	21 (533.4)	35.43 (900)	12.4 (315)
—	200		49.61 (1260)	14.17 (360)
—	250			
—	300			
—	350		26.91 (683.4)	51.18 (1300)
—	450	26.94 (684.2)	63.78 (1620)	
—	500	34.81 (884.2)	64.17 (1630)	19.75 (501.6)
—	600		39.54 (1004.2)	
—	700	39.54 (1004.2)	64.57 (1640)	19.75 (501.6)
—	800			
—	900	39.54 (1004.2)	64.57 (1640)	19.75 (501.6)
—	1000			

**40 HP or below**

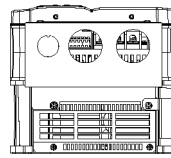
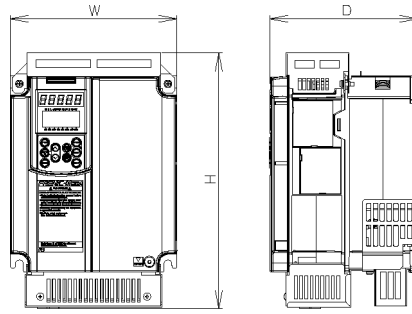

**50 HP or above**

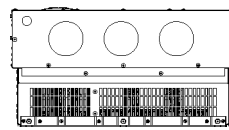
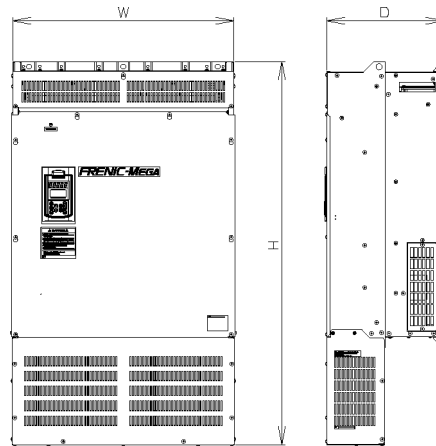

**Note:** Standard models with NEMA1 kit cannot employ external cooling.

# Keypad (TP-G1W-J1)

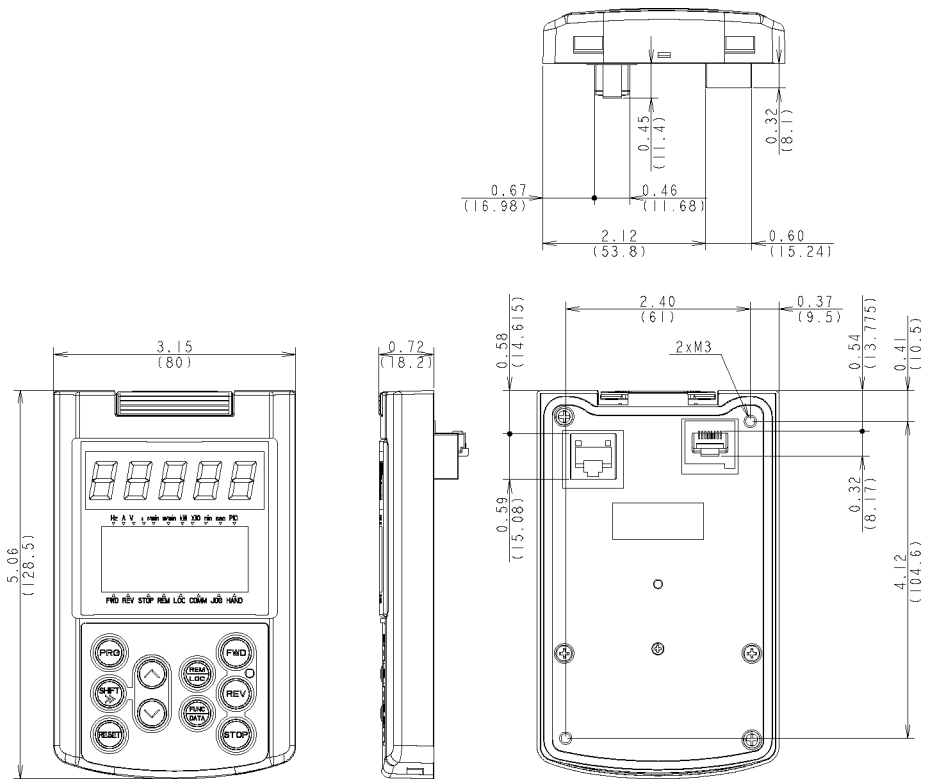

Drill four screw holes and cut a square hole in a panel as specified below.

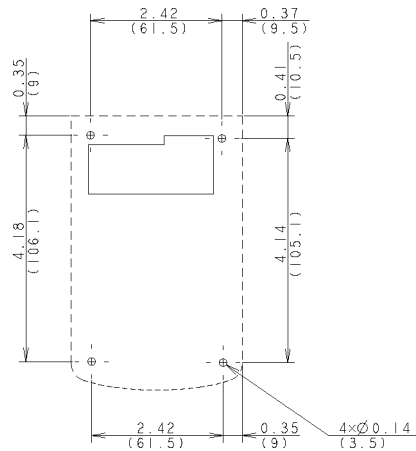

Location of Screw Holes in Panel (viewed from back)

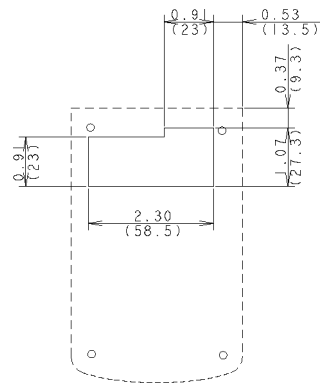

Dimensions of Panel Cutting